

Intruder Detection and Forest Fire Alert System with Using Wireless Sensor Network

D.Vignesh Kirubaharan¹, A.John Clement Sunder², S.M.Ramesh³, P.Dhinakar⁴

PG Scholar, Department of ECE, Bannari Amman Institute of Technology, Erode, T.N, India ¹

Associate Professor, Department of ECE, Bannari Amman Institute of Technology, Erode, T.N, India ²

Associate Professor, Department of ECE, Bannari Amman Institute of Technology, Erode, T.N, India ³

PG Scholar, Department of ECE, Bannari Amman Institute of Technology, Erode, T.N, India ⁴

Abstract: As humans advanced in technology, manmade and natural disasters are increasing exponentially. One of the most dangerous is the forest fire. Forest fire destroys trees which give us oxygen and it is very difficult to stop a forest fire spreading if it is not detected early. Our method is to detect the forest fire as early as possible and also predict the forest fire in advance so that prompt action can be taken before the fire destroys and spreads over a large area. We also find the rate of spread of fire in all direction so that necessary action can be initiated. The other problems are deforestation where humans cut the trees from restricted areas and so the wild animals from the forest enter the human habitation and cause problems. In this paper we discuss the solutions to overcome these problems.

Keywords: Fire detection, humidity sensor, temperature sensor, Intruder detection

I. INTRODUCTION

Several million acres of forest are destroyed every year due to forest fire. Forest fire not only destroys many valuable trees but also destroys the vegetation in that area. The fire will burn the trees and also the soil is burnt and so many acres of land become water repellent. Forest fire is one of the major causes of global warming as tones of greenhouse gases are emitted into the atmosphere. Nowadays the detection mechanisms used are watching towers, satellite imaging, long distance video recording, etc. But these do not provide quicker response which is most important in forest fire detection. Video surveillance is a low cost system but it produces false alarm due to environmental condition like fog, clouds, dust and human activities. Another method uses visual camera to take snapshot of the forest. This camera is placed on towers so that a maximum area of the forest is covered. A motor is used to rotate the camera 360° so that we get a full view of the forest. The images obtained using these cameras are processed using a program or a MATLAB code. These images are used to find forest fire by comparing it with the normal images. The advantage of this method is that the system can be programmed to take into considerations of the environmental conditions and the effect of fog or clouds can be eliminated. The serious disadvantage is that it may sometime do not predict the fire considering the signals are due to environmental conditions. We also need to build towers to place the camera at a higher position and this may increase the cost of the system. A good and effective method is the use of wireless sensor network. In this method the sensor module is deployed in the forest manually or through helicopter. The sensor module consists of multiple sensors like temperature sensor, humidity sensor, etc. They collect the target environment information and continuously transfer it to the control center where the necessary process is carried out. Sensor nodes are less costly and even if it gets damaged in fire it

won't be a great loss. WSN has the property of self configuration and hence need not be organized manually. Using GPS the exact location of the fire can be easily obtained and the nearest fire service can be easily informed using GSM. To detect the entry of humans into the restricted areas of the forest and the entry of wild animals into the villages we use IR or laser transmitter and receiver and solve the human animal conflict in the forest areas.

II. PROPOSED FIRE DETECTION MECHANISM

The proposed method consists of standalone boxes, with each box consisting of various sensors like humidity and temperature sensors. These boxes are spread around the entire forest area so that a complete coverage is obtained.

A. Sensor Deployment

Sensor deployment is most significant factor as it determines the efficiency of the entire system

1. The sensor should cover the entire forest with minimum number of nodes
2. The distance between the sensors must be equal so that it is easy to calculate the rate of spread of fire
3. The sensors must be positioned such that false alarms are avoided

These sensors collect the data wirelessly and transmit the data to a base station. The sensors form a cluster and are active always.

They sense the parameters every 15 minutes and if there is a possibility of fire detected then the parameters will be measured every 2 minutes. This is to reduce the usage of battery power. These sensors cannot be powered using electricity as they need to be deployed deep into the forest hence rechargeable batteries that are powered by solar panels are used.

B. Topology Design for fire detection

The topology of the sensor nodes must be pre planned based on the density of trees in the area. When the density of trees is more then there are more chances of fire as the trees more often rub each other producing heat due to friction. In such cases the number of sensors deployed must be higher. While considering the energy restriction the detection of forest fire as early as possible must not be compromised.

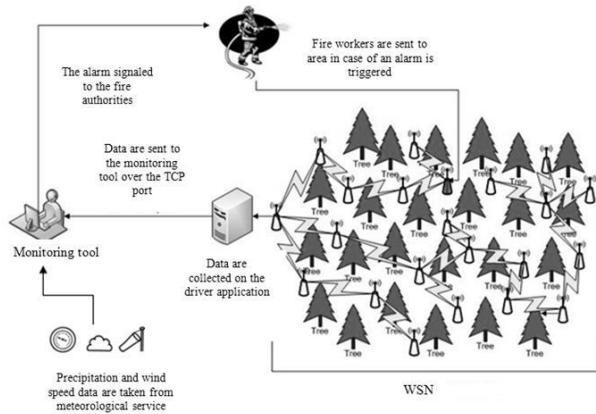

Fig. 1. Deployment of sensor

C. Topology Design for Intruder Detection

The intruder detection is done using the laser beams. The other methods for the intruder detection mechanism are using video and image processing using cameras but the disadvantage in this method is that false alarms are caused due to bad weather conditions like fog, rain, etc. As lasers can penetrate fog this method does not produce any false alarm. But any small birds or debris due to air will cause false indications but this problem can be eliminated by considering the size of the objects.

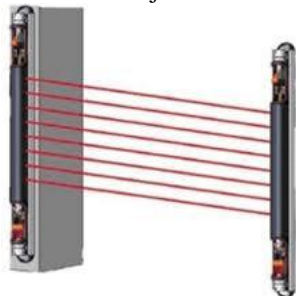

Fig. 2. Use of laser beam for intruder detection

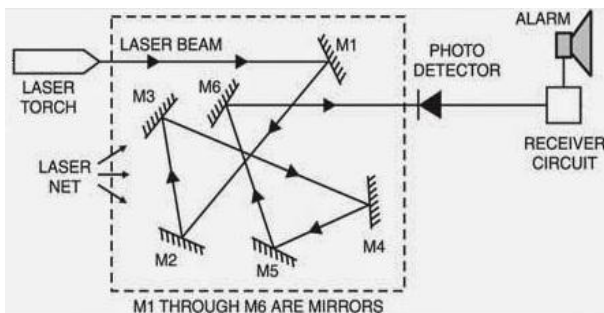

Fig. 3. Use of mirrors to form a mesh of laser beam

This network is deployed at the boundary of the forest only as the detection needs to be done only at the edges of the forest. We can detect both the entry of humans into the restricted areas of the forest and also exit of wild animals

from the forest. The areas of unwanted detection can be blanked to avoid unnecessary alarm. The main advantage of this detection mechanism is it is contactless and can define the target size and other parameters for activation of the alert.

III. MATERIALS USED

A. Temperature Sensor

One of the main changes that happen when a fire occurs is the increase in temperature of the environment. This might be the cause of forest fire or due to change in temperature during summer. The change in temperature due to forest fire can be differentiated from other environmental factors as the rate of change of temperature due to fire will be rapid. Here LM35 is used as fire sensor and this can measure the temperature in the range of -55°C to 150°C .

B. Humidity Sensor

The measurement of humidity can be greatly used to detect and predict the fire. When a fire occurs the air becomes dry and the humidity will be low. And there is a maximum possibility of occurrence of fire when the air is dry than being moistures.

C. Battery

The battery used for this project must be rechargeable, small, light, cheap, environmental friendly, fast in charging and discharging, reliable, long lasting, etc. Not all these are satisfied in one battery but Li-ion battery seemed to suit the purpose.

D. GSM

GSM (Global System for Mobile communication) is a digital mobile telephony system that is widely used in Europe and other parts of the world. GSM uses a variation of time division multiple access (TDMA) and is the most widely used of the three digital wireless telephony technologies (TDMA, GSM, and CDMA).

GSM digitizes and compresses data, then sends it down a channel with two other streams of user data, each in its own time slot. It operates at either the 900 MHz or 1800 MHz frequency band. GSM is used to send status about the occurrence of fire in the forest. GSM is interfaced to the microcontroller through RS 232 to USART terminals [8].

E. Zigbee

Zigbee is a specification for communication in a wireless personal area network (WPAN). Zigbee is based on an IEEE 802.15 standard. It consumes low power with transmission distance of 10 to 100 meters line of sight. It can transmit data over long distance through intermediate devices such as by forming mesh network.

Zigbee has a defined rate of 250 Kbit/s, best suited for intermittent data transmissions from a sensor or input device. It is simple and much less expensive than other WPANs such as Bluetooth and Wi-Fi.

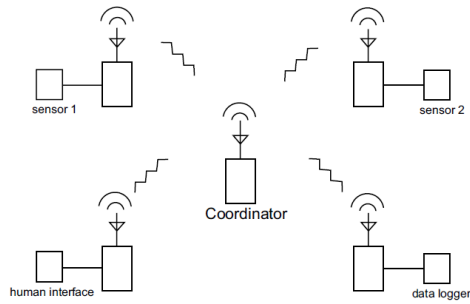

Fig. 4. Zigbee based sensor network

IV. ALGORITHM FOR FIRE DETECTION

1. All the nodes are initialized and synchronized to same clock
2. A cluster of nodes are connected a base station and all the base station are connected to the control center
3. LM 35 senses the temperature and transmit it to the base station every 30 minutes when the humidity of air is high
4. When the humidity of the air reduces there is more possibility of fire hence the rate of measurement is increased to every 15 minutes
5. If the temperature is less than the threshold value the node enters the sleep state else the sensor continuously senses the temperature and transmits the result to the base station
6. When a node senses fire it sends a danger packet to its neighboring nodes and the timer is started and the timer is run till it gets a fire alert. This is to calculate the rate of spread of fire and the direction of spread
7. The base station collects all the values and calculates the rate and direction of spread of fire
8. Through the GSM, alert messages is sent to nearby villages to relocate the people to a safe locality

This is a simple method where we have a less overhead in the data packets, and this topology is easy to expand. The energy consumption is also less as the node senses the parameters only on certain intervals which are controlled by the base station [4].

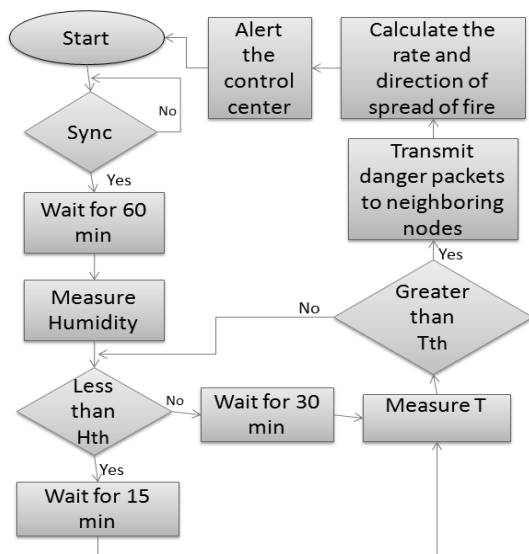

Fig. 5. Flow chart

V. CIRCUIT DIAGRAM

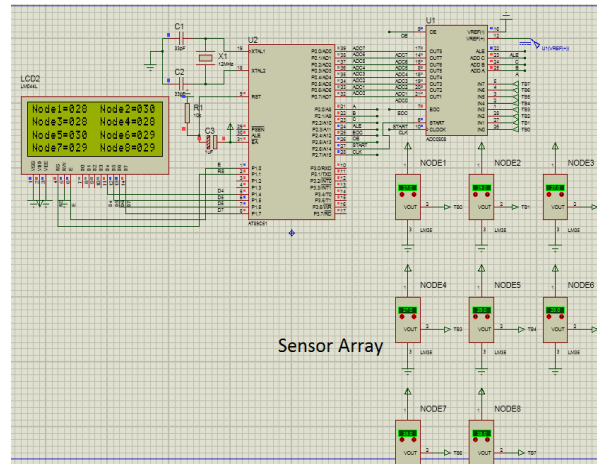

Fig. 6. Circuit diagram with sensor array

In the above circuit an array of sensors is connected to a controller through an ADC. The clock signal to the ADC is adjusted such that the parameters are measured at a particular interval of time. The LCD display shows the temperature at all nodes. When the number of nodes is higher, GPS can be used to locate the nodes.

VI. WORKING OF FIRE DETECTOR

A. Prediction of fire

It is necessary for us to detect the fire as early as possible and occurs when the humidity of the air is lower and the temperature is higher. Thus if the humidity of the air is below a threshold value and the temperature is higher than the threshold value then an alert signal is sent to the control center.

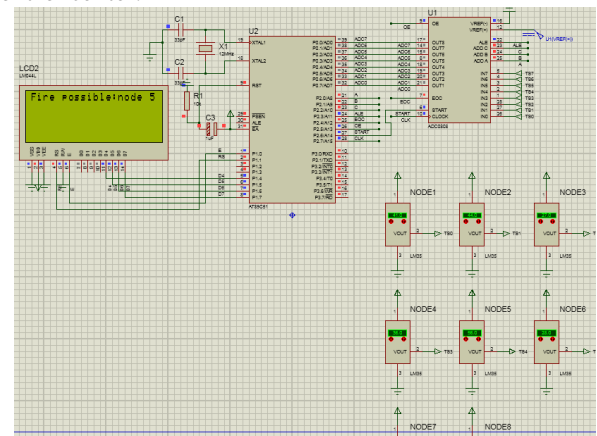

Fig. 7. Fire predicted based on the sensor values

Once the fire is predicted at a particular location then the necessary precautionary measures are carried out. The fire may occur even without being predicted. This prediction will work only when the fire arises due to increase in the relative temperature but when the fire occurs due to incidents such as lightning or manmade events then the fire cannot be predicted.

B. Detection of Fire

When the temperature in a particular node gets increased over a fixed threshold value then the alert is sent to the control center. The threshold value is always fixed above the maximum temperature which is experienced in that

particular region to avoid any false alarm due to the increase in the atmospheric temperature.

As soon as the fire is detected in a particular node the alert is sent to the control center and also to the neighboring nodes. Once the nearer nodes get the alert, timer is started and it is run till the nearer node detects the fire. This is to find the rate of spread of the fire in the forest. When the rate of spread is known then the necessary action can be taken quickly. All the nodes are equally spaced in order to easily find the rate of spread of fire. The rate of spread directly depends on the speed of air blowing. And also the fire usually spreads upwards in a hilly area. These are taken into considerations while designing the detection system.

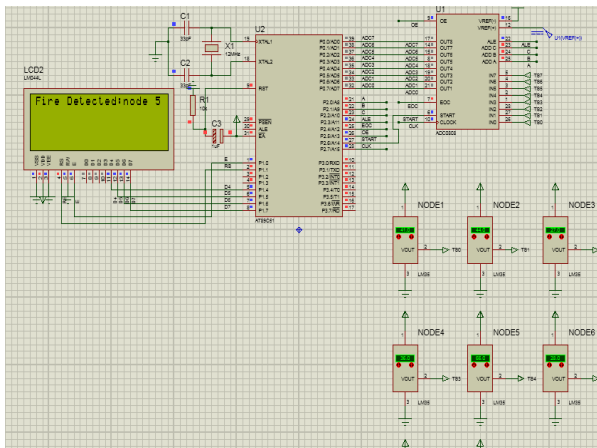

Fig. 8. Fire detected at node 5

The temperature at node 5 increases beyond the threshold hence an alert is displayed in the screen.

C. Finding the direction and rate of spread of fire

The direction of spread of fire is more important to prevent further damage to the forest and wildlife. This can be obtained by using the data collected from the sensor nodes. Normally the fire spreads in all the directions hence when a fire is detected in a node then it sends danger alert packets to all the neighbouring nodes and all the neighbouring nodes start a timer and measure the time between the reception of the alert packets and the detection of fire. This is done for all the neighbouring nodes.

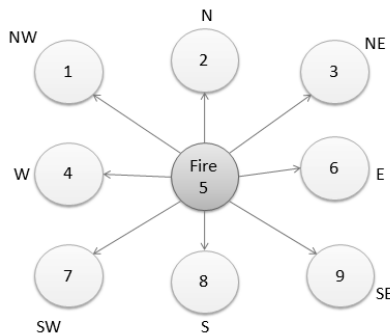

Fig. 9. Fire detected node sending alert packets to neighboring nodes
In the above method the middle node 5 detects the fire first and it sends alert packets to all eight neighbors. Hence the rate of spread of fire in all the eight directions can be found.

$$\text{Rate of spread of fire} = \frac{\text{Distance between two nodes}}{\text{Time interval between reception of alert and fire detection}}$$

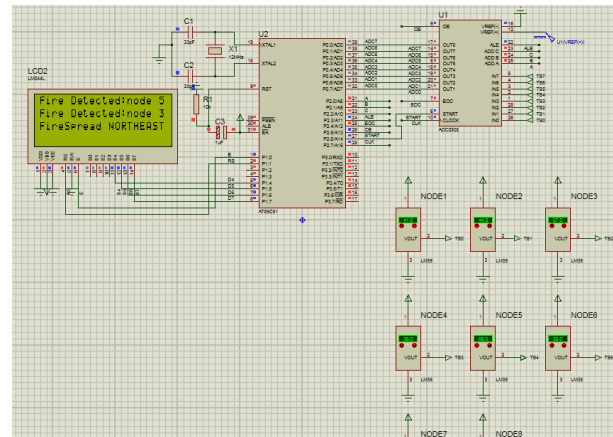

Fig.10. Direction of spread of fire

D. Intruder detection

The Laser beam is passed from the source to the photo diode in the region where the unauthorized access must be detected. Mirrors are placed in the path between the laser source and the photo receptor to increase the coverage area. Parallel beams of laser are used so that the size of the object obstructing the path is obtained and the alarm or the alert is not sent when the size of the object is small like a bird or insect. The direction of the entry is obtained so that we can know whether it is a human or an animal leaving the forest.

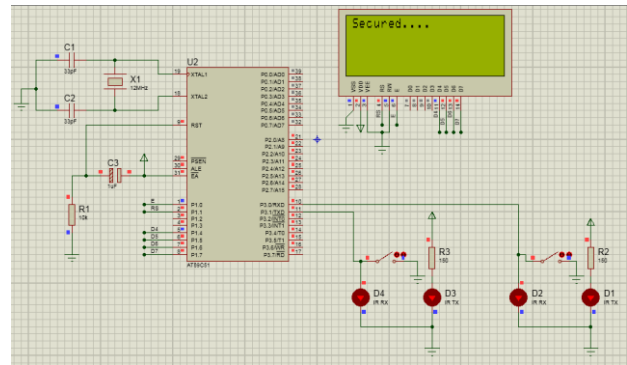

Fig.11. No Intruder Detected

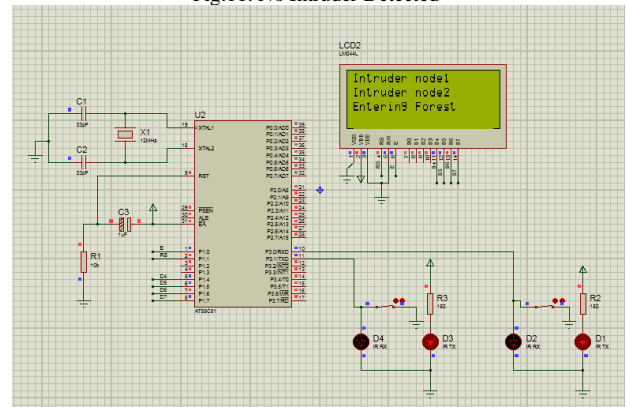

Fig.12. Intruder Entering Forest is detected

A camera is placed at the sensor nodes and when an alert is detected, the camera captures images of the object and sends it to the control room and hence necessary actions

are taken immediately. Nowadays a large number of cases of animals from the forest entering the villages and killing people and livestock are being reported. This system will be more useful in tracking wild animals and their movement in the forest. We could easily trace the location of the trespassing and alert either the forest department or the village people in that locality. This system can be enhanced by adding a sensor module for detecting illegal logging of valuable trees from the forest.

REFERENCES

- [1] T. Akyildiz, W. Su, E. Cayirci, and Y. Sankarasubramaniam, "A survey on sensor networks," in *proc. of IEEE Communications Magazine*, vol.140, no. 8, pp. 102-114, Aug.2002.
- [2] C. F. Garcia Hernandez, P. H. Ibargliengoytia-Gonzalez, J. , J.A. Perez Diaz and Garcia Hernandez," Wireless Sensor Networks and Applications a Survey," *International Journal of Computer Science and Network Security*, vol.7 no.3, Mar. 2007.
- [3] A. Mainwaring, D. Culler, R. Szewczyk, and J. Anderson."Wireless sensor networks for habitat monitoring", In *Proc. of the First International Workshop on Wireless Sensor Networks and Applications (WSNA'02)*, pages 88-97, Atlanta, Georgia, Sep. 2002.
- [4] Ajay V. ,Chetan B., Ganesh S., Kumaran S., "Sensor Nodes Approach to Forest fire Prediction and Prevention," *Stony Brook University*, 2009.
- [5] Stipaničev, D., et al., "Forest Fire Protection by Advanced Video Detection System- Croatian Experiences" *Split, Croatia*, 2006.
- [6] D. M. Doolin and N. Sitar, "Wireless Sensor Nodes for Wildfire Monitoring", *SPIE Symposium on Smart Structures and Materials*, San Diego, pp. 477484, 2006.
- [7] D. Morvan, M. Larini, J. L. Dupuy, A. I. Iranda, J. Andre, O. Sero-Guillaume, P. Cuinas, "Behavior Modeling of Wild land Fires: A State of the Art", *EUFIRESLAB: Euro-Mediterranean Wild land Fire Laboratory*, 2002.
- [8] Wikipedia, the free encyclopaedia, RS-232, [Online], Available at: <http://en.wikipedia.org/wiki/RS-232>
- [9] C-Y. Lin, W -C.Peng and Y-C. Tseng, "Efficient in-Network Moving Object Tracking in Wireless Sensor Networks," *IEEE Trans. Mobile Computing*, vol. 5, no.8,pp.1044-1056, 2006.
- [10] H. Kung & D. Vlah, " Efficient Location Tracking Using Sensor Networks," *Proc. IEEE Wireless Communication and Networking Conf.*, vol.3, pp. 1954-1961, Mar. 2003
- [11] S. X. Wu, W. Banzhaf, "The use of computational intelligence in intrusion detection systems: a review", *Applied Soft Computing*, vol 10(1), pp. 1-35, 2010.