

Experimental Evaluation of Concentrated Parabolic Dish Type Solar Desalination System with Coated Absorber Unit

Amar S. Sawant¹, N.N. Shinde², P.S. Patil³, M.M. Wagh⁴

M. Tech. Student, Dept. of Energy Technology, Shivaji University, Kolhapur, India¹

Dept. of Energy Technology, Shivaji University, Kolhapur, India^{2,3,4}

Abstract: Solar stills are well proven technology for water desalination but these technologies are not very popular mainly due to its low amount of productivity. For addressing this problem and to out find new alternative technology for water desalination, in this work we design, develop and experimented concentrated parabolic dish type solar desalination system with coated absorber unit. The parabolic dish made of G.I. and silver coated selective surface sheet coupled with black absorber unit, this is fix at the focal point of dish. The test result shows very good performances in terms of enhanced distill output and lower amount of heat losses from absorber unit. The experimentation carried out as per the standards at Shivaji University, Kolhapur (16°41'30"N and 74°14'00"E) in Southern Maharashtra, India.

Keywords: solar energy, desalination, concentrated parabolic dish, absorber unit.

I. INTRODUCTION

Water is life! Availability and access to clean water is the basic need and fundamental right of humans. On the earth large amount of water available in the form of saline water. Therefore it is necessary to convert this saline water into potable water. The large amount thermal energy received from the sun to the earth. This energy can be utilized for various thermal applications.

Delany E. states that, the history of mankind proves that water and civilization are two inseparable entities. They said all great civilizations were developed and flourished near large sources of water. Rivers, seas, oases, and oceans have attracted mankind to their coasts because water is the source of life. History proves the importance of water in the sustainability of life and the development of civilization. Maybe the most significant example of this is Indus valley civilization in India. The river provided water for irrigation and mud full of nutrients. Another one is the Ancient Egypt civilization who becomes as an agricultural nation and the main wheat exporting country in the world. [1] Malik et.al works on the solar still to improve the evaporation rate to enhance the distill output. [2] Gudekar et.al works on Compound parabolic collector (CPC) system for the application of process steam generation. An experimental demonstration unit having an aperture area of nearly 30 m² was set up and tested for steam generation. Their performance analysis of the system shows potential of improving thermal efficiency up to 71%. [3] Atul Sagade and N.N shinde worked out thermal performance of parabolic dish solar water heater with truncated cone shaped helical coiled receiver made up of copper and coated with nickel chrome at focal point. Instantaneous efficiency of 63.9% has been achieved with the system explained in this paper. [4] An improvement in the CPC design has been suggested by the Jadhav et.al. They bring down its height, without much compromise on the concentration ratio. A prototype of this modified CPC design was constructed and tested for thermal efficiencies and achievable temperatures. Results show that the modified CPC design can harness the solar energy to provide low cost Industrial Process Heat. [5] Maximum collection and utilization of solar energy is achieved in concentrating collector and it can be achieved in short period of time. The shape of solar concentrator is normally taken in the form of parabola. The temperature attained is in the range of 250° C. [6] from the literature survey we get the idea about Parabolic dish with absorber unit can be used for generation of steam and further it can be cools down to getting the distill output with proper modification in system.

II. DESIGN AND EXPERIMENTATION

2.1 Design of Parabolic Dish [7]

Measurements of the dish were taken to calculate the equation to describe the shape of it. The dish is considered to be that of a parabolic concentrator with a diameter (D) 1.4 meters and a depth (H) of 0.38 m. The surface area of the dish is thus calculated by the following equation:

$$A_{\text{surface}} = \frac{2\pi}{3p} \times [\sqrt{(\frac{D^2}{4} + p^2)} - p^3]$$

Where,

$$p = \frac{D^2}{8H}$$

$$p = \frac{1.4^2}{8 \times 0.6447}$$

$$p = 0.6447$$

Therefore, the surface area of the dish is thus calculated by,

$$A_{\text{surface}} = \frac{2\pi}{3p} \times \left[\sqrt{\left(\frac{D^2}{4} + p^2\right)} - p^3 \right]$$

$$A_{\text{surface}} = \frac{2\pi}{3 \times 0.6447} \times \left[\sqrt{\left(\frac{1.4^2}{4} + 0.6447^2\right)} - 0.6447^3 \right]$$

$$A_{\text{surface}} = 1.9295 \text{ m}^2$$

Thus area of concentration is calculated by equation,

$$A_{\text{conc.}} = \pi \times R^2$$

$$A_{\text{conc.}} = \pi \times 0.7^2$$

$$A_{\text{conc.}} = 1.54 \text{ m}^2$$

The resulting surface area of the concentrator is 1.54 m^2 . The cross-section of the concentrator can be viewed as a parabola, which is given by the equation,

$$f(x) = ax^2 + b$$

Where $f(x)$ is the function describing the shape of the parabola, x is the horizontal distance from the center, and the constants a and b describe the shape of the parabola. b can be made zero by placing the bottom center of the concentrator at the origin. From this constraint, the value of $f(x)$ is equal to the depth when x is equal to the radius of the dish.

Thus, the constant a can be calculated using the following equation:

$$a = \frac{\text{Depth}}{\text{Radius}^2}$$

$$a = \frac{0.38}{0.7^2}$$

$$a = 0.7755$$

This constant is used to determine the focal length of the collector. The focal length of the concentrator is defined as the distance from the bottom of the parabola to the concentration point (focal point). For a symmetric parabola, the focal point lies along the axis of symmetry where the distance above the intersection of the axis and curve gives the focal length by,

$$\text{Focal length} = \frac{1}{4a}$$

$$\text{Focal length} = \frac{1}{4 \times 0.7755}$$

$$\text{Focal length} = 0.3223 \text{ m}$$

Thus establishing where there focal point is located relative to the bottom of the concentrator.

The calculation of the focal length is useful for positioning of the receiver, however, due to the dynamics involving the sun, earth, and optics of the concentrator, the focal point will not be an exact point, but will actually be more of a focal area.

2.1.1 Tracking of dish

Tracking of the parabolic dish is done manually to reduce the costs. For this purpose a bar is attached on tracking axis such that when shadow of bar is at its bottom solar rays are exactly perpendicular to collector surface and maximum concentration of rays at focal point.

2.2 Design of Absorber Unit

Absorber is nothing but steam generation unit which gives distill water output. While considering the losses from the absorber it is convenient to select the enclosed body of absorber. While designing the absorber we consider the focal area dimensions for maximum yield generation from it. Other details of absorber as follows-

Table 1. Specifications of Absorber Unit

Name	Specification
Material	Aluminum
height	0.14m
Weight	1.45 kg
Diameter	0.21m
Capacity	4 litre
Thermal conductivity	205 w/mK
Emissivity	0.2

2.3 Layout of System

Table 1 System Components Details

Sr. No.	Component Name	Material	Qty.
1	Parabolic Dish Sheet	Silver coated Ionized Al	1
2	Absorber Unit with Coating	Al	1
3	Pipe 1	Plastic	1
4	Pipe 2	Steel	1
5	Collection Flask	Plastic	1
6	Dish Stand	GI	1

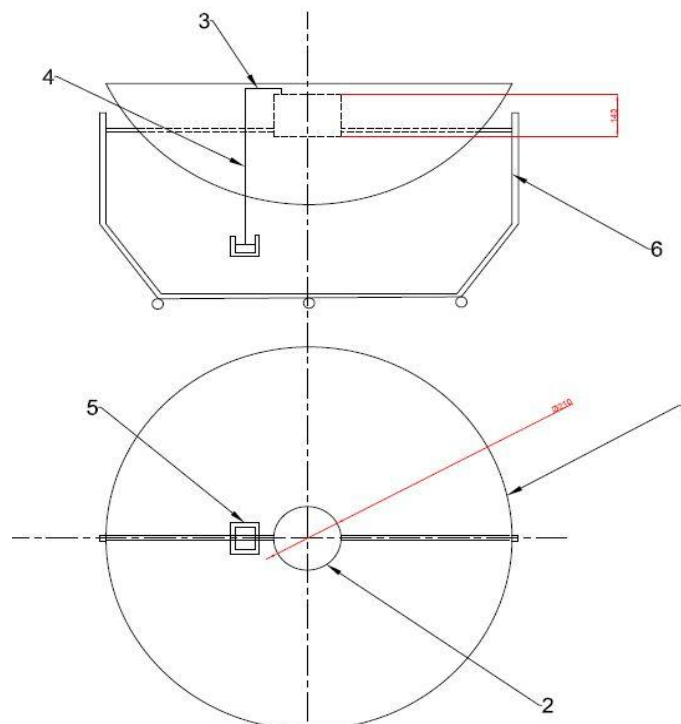

Fig.1 Layout of System

2.4 Test Procedure and Instrumentation

2.4.1 Test procedure consists of following steps:

- Measuring quantity of water before test which in absorber
- Proper orientation of dish in sun facing direction so that concentrated rays falls on focal point
- Connection of K type thermocouple with interface of data logger at various location on absorber for measuring heat losses from it
- Measuring quantity of distilled water output.
- Measuring readings of wind sensor, pyranometer and data logger

2.4.2 Instrumentation for data collection

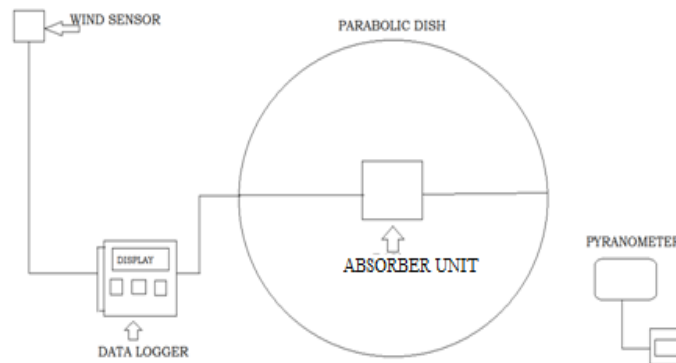

Fig.2 Test Set up Layout

2.5 Heat Loss Calculations from the Absorber Unit [8]

The heat losses from absorber in terms of an overall loss coefficient defined by the following equation,

$$q_l = U_l \times A_a \times (T_a - T_{air})$$

The heat loss from the absorber is sum of the heat lost from the top and the sides of absorber.

Thus,

$$q_l = q_t + q_s$$

Where,

q_t = rate at which heat is lost from the pot cover

q_s = rate at which heat is lost from the sides of the absorber

Each of these losses is expressed in terms of coefficients called the pot cover loss coefficient and defined as,

$$q_t = U_t \times A_a \times (T_a - T_{air})$$

$$q_s = U_s \times A_a \times (T_a - T_{air})$$

Where,

$$U_l = U_t + U_s$$

The rate of convective heat transferred from absorber to surrounding air was determined using the given relation,

$$Q_{con,a-air} = (T_a - T_{air})(5.7 + 3.8V)[2\pi rh]$$

The radiative heat transferred from absorber to sky was determined using the given relation,

$$Q_{rad,a-sky} = 2\pi rh\sigma\epsilon[T_a^4 - 9.28 \times 10^{-6}T_{air}^6]$$

The conductive heat transferred from absorber to fluid was determined using the given relation,

$$Q_{cond,a-f} = h\pi r_c^2(T_c - T_{air})(5.7 + 3.8V)$$

The radiative heat transferred from pot cover to absorber was determined from the given relation,

$$Q_{rad,c-air} = \frac{\sigma A(T_a^4 - T_c^4)}{\frac{1}{\epsilon_c} - 1}$$

Overall heat loss,

$$Q_{total} = Q_{con,a-air} + Q_{rad,a-sky} + Q_{conv,c-air} + Q_{rad,c-air}$$

Overall heat loss coefficient,

$$U_l = \frac{Q_{total}}{A(T_a - T_{air})}$$

III. RESULT AND DISCUSSION

3.1 Effect on Distill Output

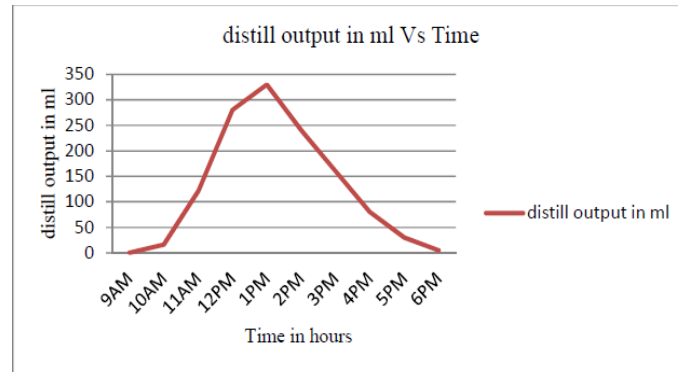

Graph 1

Graph 1 shows the time Vs distill water output. From 10 AM distill water generation pick up suddenly and between 11 AM to 1 PM gives maximum output due to availability of higher amount of direct solar radiation. As radiation intensity decreases distill water output slows down. For this test we get 330 ml/hr maximum output. At the end of test, we get total 1261 ml distill water output.

3.2 Effect of Total Heat Losses

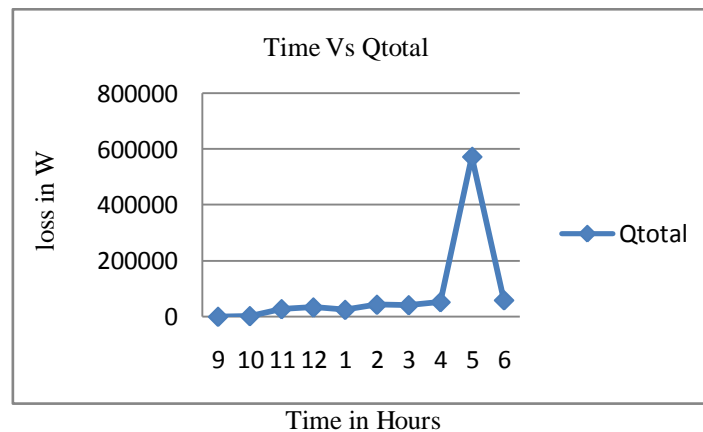

Graph 2

Graph 2 shows the time Vs total heat losses from the absorber. The total heat loss pattern is not uniform and it varies over the time. This Happens mainly due to the wind speed variation around the system. Which carries the some amount of heat from the absorber and fluctuations occurs in total heat losses.

IV. CONCLUSION

From the experimentation we get 1261 ml/day distill water output at the end of day, it gives good amount of distill water output while comparing with the simple solar still. The steam carrying composite pipe from the absorber unit to the distill water collection flask very effectively condenses the steam and gives higher amount of distill water output. Here no need of separate condenser or heat exchanger. Also we found minimum heat losses from absorber unit with higher generation capacity due to coated surface. Thus this system proves alternative to the other water desalination methods and mainly benefited with eco friendly manner, enhanced distill output capacity and minimum heat losses.

ACKNOWLEDGEMENT

The authors gratefully acknowledge Contributions of **Prof. Atul A. Sagade**, Principal, New Satara College of Engineering and Management (Polytechnic), Pandharpur, India for their valuable guidance and constructive support.

REFERENCES

- [1] Delyannis E., Historic Background of Desalination And Renewable Energies, *Solar Energy* 2003;75(5):357–66.
- [2] M.A.S. Malik, G.N. Tiwari, A. Kumar, M.S. Sodha, *Solar Distillation*, Pergamon Press, Oxford, UK, 1982.
- [3] Ajitkumar S. Gudekar, Atul S. Jadhav, Sudhir V. Panse, Jyeshtharaj B. Joshi, Aniruddha B. Pandit; Cost effective design of compound parabolic collector for steam generation; *Solar Energy*, 2013; 90:43–50
- [4] Atul A. Sagade, Comparative Experimental Analysis Of The Effect Of Convective Heat Losses On The Performance Of Parabolic Dish Water Heater, *International Journal of Sustainable Engineering*, 2013; 6:258-266
- [5] Atul S. Jadhav, Ajitkumar S. Gudekar, Ramchandra G. Patil, Dhanaji M. Kale, Sudhir V. Panse, Jyeshtharaj B. Joshi, Performance analysis of a novel and cost effective CPC system *Energy Conversion and Management*, 2013; 66:56–65
- [6] Sukatme S.P., *Solar Energy*, 2nd edition, Tata McGraw-Hill Publishing Company Ltd.
- [7] D. Yogi Goswami, F.Kreith J.F. Kreider; *Principals of solar engineering*; Philadelphia, USA; Taylor and Fancis; 2003
- [8] Dasin Dahiru Yahya, Experimental Investigations Of Heat Losses From A Parabolic Concentrator Solar Cooker, *African Journal Of Engineering Research* Vol. 1(3), Pp. 90-96, August 2013
- [9] Satish Aher, Atul A. Sagade, N.N. Shinde, P.D. Haridas, Experimental investigations on black epoxy coated aluminium receiver with FRP parabolic trough collector, *International Conference on Energy Efficient Technologies for Sustainability (ICEETS)*, 2013; pp 291-299
- [10] H.P.Garg, J.Prakash, *Solar Energy Fundamentals And Applications*, 1st ed. New Delhi, Tata McGraw Hill 2000
- [11] Sagade Atul. and Shinde N. Performance Evaluation Of Parabolic Dish Type Solar Collector For Industrial Heating Application', *Int. J. Energy Technology and Policy*, 2012; 8:80–93.
- [12] Mr. Atul A. Sagade, Prof. N.N. Shinde, Mr. Sailesh Patil, Experimental Investigations on Mild Steel Compound Parabolic Reflector with Aluminum Foil as Selective Surface and Top Cover, *Science Direct, Energy Procedia*, 57 (2014), 3058 – 3070
- [13] Mr. Atul A. Sagade, Prof. N.N. Shinde, Prof. Dr. P.S. Patil, Effect of receiver temperature on performance evaluation of silver coated selective surface compound parabolic reflector with top glass cover, *Science Direct, SHC 2013, International Conference on Solar Heating and Cooling for Buildings and Industry* September 23- 25, 2013, Freiburg, Germany, *Energy Procedia*, 48 (2014) 212 – 222

BIOGRAPHY



Amar S. Sawant, B.E. Mechanical Engineering, M. Tech. (Research Student), Energy Technology, Shivaji University, Kolhapur, India