

“Listening Dumb through Tactile Sign Language by using Image Processing”

Indrayani Tembhe¹, Shivani Pimpalkar², Shubham Chauragade³, Sushmita Sonbarse⁴, Jyotsna S. Gawai⁵

Electronics Department, K.D.K.C.E, Nagpur¹⁻⁵

Abstract: Communications between deaf, dumb and a normal people have always been a difficult task. Approximately 9 billion people in the world are deaf and dumb. The communication between a deaf and normal people is to be a serious problem. This project mainly addresses to facilitated deaf and dumb person's life. By this project deaf and dumb people can communicate with the normal people. Throughout the world dumb people use the sign language to communicate with the other but this is possible to understand who have enough knowledge about sign language. Common people also face problem to understand this language, to recover this problem, we developed the system for dumb and deaf people.

Keywords: Image processing, Raspberry Pi, Text to speech, open CV, gesture reorganization, machine learning

I. INTRODUCTION

Sign language is a hand gesture language, which visually transmit sign pattern using hand –shapes, orientation and movements of the hand, arms or body, facial expression and lips pattern to convey words meaning consist of acoustic sound patterns. The signs recognize for deaf, voice recognizes for blind people and text recognize for both deaf and dumb people. Different signs language exist around the world, each with its own vocabulary and gestures. This languages commonly use in deaf community including friends and family of the deaf as well as people who are not able of hearing themselves. In their daily life, the communication is the main problem to interacting with the normal people. The sign language recognizes the sign language pattern such as hand movements, body movements, lips movements, etc. It is not possible for all the deaf and dumb people to learn sign language to understand whatever the person wants to tell them with hand gesture language, Therefore communication gap is still between them with normal people. To solving these difficulties like vocally impaired person, we use the small size system called tactile sign language, by this device we are facilitate them. The importance of this sign language is increasing in the public interaction and therefore found for international project. Image processing is the basic technique we are use in this project. This system can automatically convert the sign language into text.

II. AIM AND OBJECTIVE

In this paper, The main aim is build up a smart communication system called tactile sign language, to propose a sign language for deaf and dumb people by using image processing, The contributions of this paper can be summarized as below:

Motivate them (deaf and dumb) to speak in front of any one without any hesitation through our tactile sign language.

Integrate their (deaf and dumb) signs by interacting with them and because of that we facilitate them with a system called sign language.

We prove that dumb people also can speak and deaf can also hear through our system. The results show its efficiency, effectiveness and applicability.

In this paper, Objective of this project is to reduce the differences and communicate between dumb and deaf people with normal people.

To reduce their prostration during communication or interacting with normal people. This system is useful for understanding the dumb and deaf people.

III. PROPOSED WORK

In this paper the proposed work of this project is to convert the signs language to voice through tactile sign language by using open CV image processing. In this system,when power get on the raspberry pi provide input through camera which is connected in it, first the camera detect the signs which are programmed in the system or data base. Then detected signs gets converted into voice by using image processing, the image get detected throug some angle betwn the fingers. The angles of the fingers on screen to form voice.

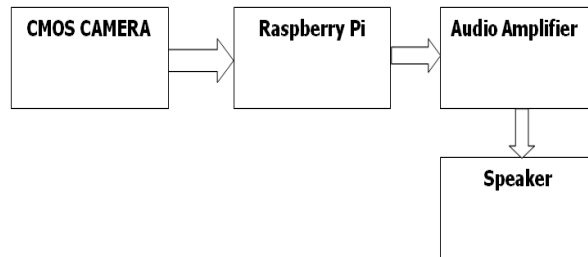

Fig1.Block Diagram

IV. FLOW CHART

In simplified simply put, the process consists of four steps:

1. Start web camera.
2. Capture hand gesture.
3. Translate, Extract, match, recognize feature of Gesture using python.
4. Translate hand gesture meaning into voice.

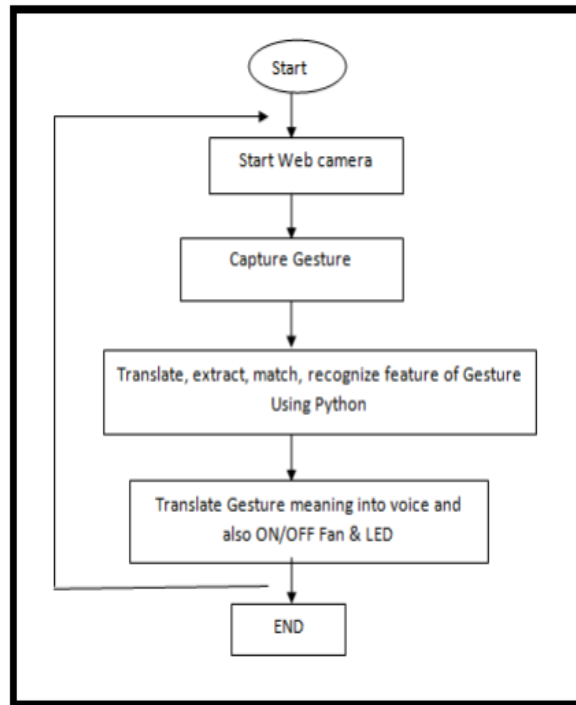

Fig 2. Data Flow Diagram

First we start the system. After that we start the web camera of the system. After we started web camera we start capturing gesture for the sign reorganization

Then hand gesture translates into sign language and reorganization the various feature of hand gesture of sign language is converted into voice reorganization.

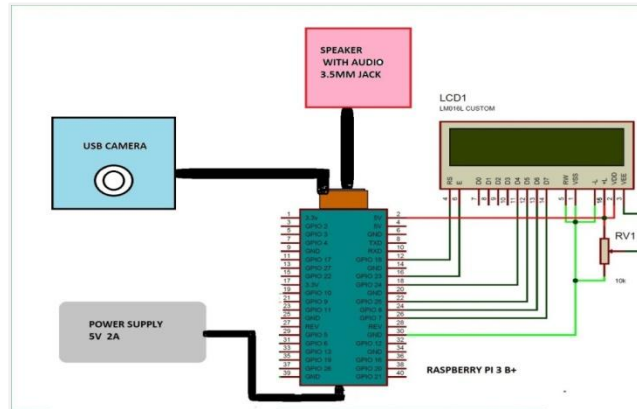

Fig 3 System Architecture

V. CONCLUSION

The major objective of this paper is to help dumb & deaf people to translate their daily interaction into text and speech format. The important key factor of this project to facilitate these people and to fix them more confident to manage their sites by themselves. This project aims to develop a useful tool that uses gesture recognition for reducing the communication barrier between the deaf and dumb community and the normal people. This project was meant to be a prototype for checking the feasibility of recognizing gestures using image processing. Using the designed project it is possible to convert hand gestures into speech which can be understood easily by normal people.

REFERENCES

- [1]. Noor Saliza Mohd Salleh, Jamilin Jais, Lucyantie Mazalan, Roslan Ismail, Salman Yussof, Azhana Ahmad, Adzly Anuar, and Dzulkifli Mohamad "Sign Language to Voice Recognition: Hand Detection Techniques for Vision-Based Approach". Current Developments in Technology-Assisted Education, 2017.
- [2]. Yuqian Chen, Wenhui Zhang, Department of Information and Engineering, communication university of China Beijing, 100024, China 16 Feb 2016.
- [3]. Urmila Sarawankar, Sayli S. Dixit IEEE member G.H. Raisoni College of Engineering Nagpur M.H India
- [4]. Sunita V. Matiwade1, Dr. M.R.Dixit, Electronic Support System for Deaf and Dumb to Interpret Sign Language of Communication, International Journal of Innovative Research in Science, Engineering and Technology, Vol. 5, Issue 5, May 2016.
- [5]. Pallavi Varma, Shimi.S.L, Richapriyadarshini, "Design of Communication Interpreter for Deaf and Dumb person" in Jan-2015
- [6]. Vasanthi.G and Ramesh Babu.Y Department of ECE, DMI College of Engineering, Chennai, India. "Vision Based Assistive System for Label Detection with Voice Output" Jan-2014.
- [7]. Chucai Yi, Student Member, IEEE, Yingli Tian, Senior Member, IEEE, and Aries Arditi "Portable Camera-Based Assistive Text and Product Label Reading from Hand-Held Objects for Blind Persons" 2013 IEEE.
- [8]. Dharanikumar Chowdary. M, M. Narasimhulu, G. Subrahmanya Sharma, "Advanced Embedded Chatter Box for Physically Challenging Persons" in Jan 2012.
- [9]. <https://projects.raspberrypi.org/en/projects/getting-started-with-picamera/4>