

Live Power Consumption Monitoring and Home Automation using Google Assistant

Saran Kumar.R.S¹, Srevignesh.S², Vijay.S³, Sivaraman.M⁴ and T.Tamilarasan⁵

Assistant Professor, Department of Instrumentation & Control Engineering, Saranathan College of Engineering, Trichy⁵

UG Final Year Student, Department of Instrumentation and Control Engineering,

Saranathan College of Engineering, Trichy^{1,2,3,4}

Abstract: Power Consumption Monitoring system is used to measure the amount of power consumed and its estimated cost for the user in home and alert system is used to send notifications to the user every 50 units before reaching the next slab. This will help the user to consume the power cautiously and as a result the cost payed by the user will be reduced. Automation system is done in order to automate the electrical appliances through IoT. This Automation system can also be used for detecting any intruders in the absence of the owner of the house. All the system are done through IoT, so that it will be more efficient and friendly to the user. The voice control of home appliances is done for more ease of the person to control their home appliances. The voice control for appliances is done using Google Assistant.

Keywords: Live Power Consumption Monitoring System, SMS and E-mail Alert System, NI LabVIEW, NI MyRio, IoT, IBM Watson Bluemix, AWS, Intruder alert system. Google Assistant

I. INTRODUCTION

Energy a powerful word in this technological world is very important part in a man's life. Without Energy nothing happens. So this Energy is harnessed in many ways but they are not sufficient for this world, so in order to meet the demand everybody should not waste the energy produced. By saving the energy produced there will be more benefits for everyone. By knowing the amount of electrical energy we consume and planning accordingly everybody can save electricity and also reduce the amount being paid for electricity every month. This paper suggests an effective way to continuously monitor the power consumed by the user and show the user the total power consumed and also the cost they should pay for the power consumed through IoT. This would reduce the power consumed by the user as they get to know all the information which would lead them to consume the power cautiously thereby reducing the bill they have to pay. IBM and AWS IoT services are used in this paper for providing all the information the user needs and also for the Notifications Alert system. The IBM IoT platform is used for displaying the total power consumed and the estimated cost to be payed. The (Amazon Web Service) AWS is used for the SMS and E-mail Alert system.

Automation of home electrical appliances done with the help of PIR sensor that detects the presence of any human and accordingly turns on/off the electrical appliances. This method provides a solution for reducing the power consumption and the cost to a greater extent. This paper's methodology uses myRIO-1900 of National Instruments as stand – alone system for performing power and rate calculations and also for publishing these calculated values in the IoT. The Current and Voltage values are obtained using the current and voltage sensors and the total power consumed and its estimated rate are calculated and they are published in the IBM IoT which can be viewed by the user. The PIR sensor is also used in the Intruder Alert system, in which presence of human is detected. This system is used during theft. When the owner of house has gone out this intruder system will be turned ON. So any other person other than the owner breaks and enters the house then an Alert message is sent to the owner and alarm is activated.

An additional feature of the Home Automation is the voice control of home appliances using Google Assistant. Google Assistant is common tool present in android phones used for helping the humans. This Google assistant can be used to control our home appliances also. So this paper shows a way how Home Automation can be done using Google Assistant.

II. LITERATURE SURVEY

Normally, the power consumption is measured by using conventional energy meters and digital energy meters are used, for measuring the live power consumption an alternative way is needed, which is done by using separate sensors for measuring current and voltage, the approach taken by [1] is similar but the way of indicating the output is like a digital energy meter, but [2] has done a different way of showing the output in a virtual machine which will run in a cloud of a

particular platform, for measuring voltage the ZMPT101B voltage sensor is used, a research has been done by [3] for accurately calibrating the sensor, [5-9] has done the method of monitoring the live power usage via IoT which is for OFF-Grid households, whereas the [6] has designed a wireless energy meter which the power usage is monitored via IoT platform, to control power usage and save the electric city the automation is needed, [4-7] has implemented automation in home for multiple purposes where [8] has implemented the IoT control of individual home appliances by which it can be turned ON/OFF.

This paper proposes the design of wireless energy meter and control of the main supply by which the total power is turned ON/OFF via IoT which also overridden by a pushbutton, the automation of home appliances(Fan, Light etc..) is done by finding the presence of humans in each room with the help of PIR sensor.

III. COST AND POWER RELATION

According to Tamil Nadu Electricity board they have a separate tariff plan for the Electricity billing. So with this tariff plan a Slab table is prepared consisting of the amount of energy consumed and cost for the consumed power. This cost factor varies according to the units consumed by the user. The below table (Fig 2) shows the divisions of slabs based on the tariffs. This paper uses this Slab table for performing the power and rate calculations.

Slab	Units consumed	Cost per Unit in rupees
Slab 1 (<100units)	0 - 100	0
Slab 2 (<200units)	0 - 100 101 - 200	0 1.5
Slab 3 (<500 units)	0 - 100 101 - 200 201 - 500	0 2 3
Slab 4 (>500 units)	0 - 100 101 - 200 201 - 500 > 500	0 3.5 4.6 6.6

Figure: 2 Tariff Slab Table

The power consumed by the electrical appliances in the house is calculated by measuring the power consumed by the appliances for the time period they are ON. In order to know the power consumed by the appliances, the voltage and the current used by them are needed. By using voltage and current sensors the current and voltage values are obtained and power is calculated by the formula $V \cdot I$.

Then this calculated power value is given as input to the MyRio for further processing. A LabVIEW program to calculate the amount of power consumed and total cost is written and uploaded into the MyRio. This final calculated values are sent to the user using IoT. The IBM IoT platform is used for showing the consumed power and cost values to the user. Now with the calculated cost for the consumed power, these values are compared with the Slab table and a SMS notification and EMAIL is sent to the user 50 units before reaching the next Slab. This helps the user to cautiously consume the power by saving Electricity and also to reduce the cost for electricity bill.

IV. MAIN DESIGN OF THE PAPER

The fig 3 shows the block diagram of the system. The NI Myrio acts as the heart of the system, which accepts all the inputs for processing and give the required output. It is like a processor that calculates the total power consumed by using the current and voltage values which are obtained from the sensor. Then this Myrio acts as a bridge way for connecting the hardware with the IoT. A LabVIEW code is written in the Myrio for performing all the required tasks of calculating the power consumed, estimate its cost and finally to display the information to the user. The Alert system is the one which notifies the user whenever the power consumed is about to reach the next slab through SMS and E-mail. With this system the user can cautiously consume the electricity thereby reducing the electricity bill and conserve electricity.

The Automation of electrical appliances is done with the help of PIR sensor using IoT. The PIR sensor is used detect the presence of any human and if there is nobody present in the room then all the electrical appliances are turned OFF. This may also help the consumer to reduce their electricity bill very much. This system help the user very much if the user have forgot to turn OFF the lights and fan in the room when they go out. The user need not worry thinking about that if they have turned OFF all the electrical appliances because it may cost them more. And the user can also turn ON or OFF their electrical appliances through IoT.

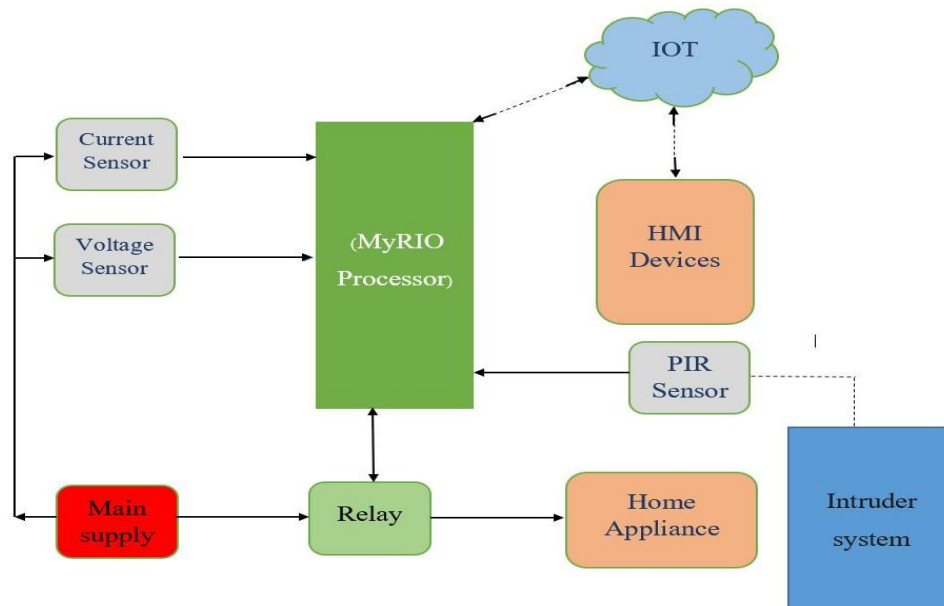

Figure: 3 Block Diagram of Energy Monitoring system

The main part of Intruder system is the PIR sensor. Using PIR sensor any motion inside the home is detected and a signal is sent to owner of the house. This system is used for security purpose when there is nobody present in the house. When going out the owner of the house turns ON the Intruder alert system, and after reaching the home again he/she can turn it OFF. So during the in between time if there is any motion detected then an alarm in the house is turned ON and a signal is sent to the owner and this signal is represented as a led in the Blynk app. In this way the owner can know about the presence of any other persons in the house. This helps in reducing the thefts.

Google Assistant a virtual Artificial Intelligence present in smart phones accepts voice commands of the person and responds with a message. It can be used to do literally anything, then why not for controlling home appliances. So the Google Assistant is used for control of Home appliances, in which a person can give a command for turning ON/OFF an electrical appliances then the Google assistant responds by turning ON/OFF the light. This system may help the physically disabled persons by giving only voice commands without moving from one place to other for turning On/OFF the appliances.

V. PROPOSED METHODOLOGY AND DISCUSSION

The overall schematic representation of the methodology used in this paper is shown in fig 4. This diagram shows all the inputs and outputs present in the system that are used to perform the calculations and other tasks. The NI MyRio is main part of the whole system where all the computation and processing works takes place. The MyRio is a product of National Instruments which can be used for both industrial and commercial applications. Myrio 1900 configuration is used in this paper and the inputs, outputs are obtained from the ports present in the Myrio. The Power calculation is done programmatically in the Myrio by getting the current and voltage values from the connected sensors. The ACS712 Current sensor is used to obtain the current flowing through main supply line. This ACS712 Hall effect based current sensor that is capable of measuring current values upto 30A. It has a sensitivity of upto 66 mA. The Voltage is measured using the ZMP101B voltage sensor which can measure voltage levels upto 250v. The voltage sensor can calibrated according to the user's requirement.

IoT part is done for the user to view the total power consumed, estimated cost for the consumed power and also for the SMS, E-mail Alert system. The IBM Watson Bluemix is a free IoT service provided by the IBM for everybody to work on IoT projects. With the help of IBM IoT service the power consumed with its cost can be viewed by the user in their mobile and computers. For the Alert system AWS (Amazon Web Service) a free IoT service provided by the Amazon is used. With AWS E-mail and SMS are sent the user every 50 units before reaching the next slab. Myrio is loaded with the LabVIEW code. It measures the power usage by getting input from the voltage sensor and current sensor and calculate the rate for the usage according to the Tariff slab table (fig 2), the calculated values are passed to the cloud for monitoring purpose, and it triggers the SMS and E-mail service 50 units before reaching the next slab.

For automation purpose, two relays are used one is the main relay and the other one is the sub relay. The main relay is connected to the main supply of the home, and the sub relay is connected for each room initially. Both the main and sub relays are in NC (Normally Closed) mode initially. The main relay is controlled by IoT which can also be overridden

by a pushbutton for any worst-case. The sub relay is turned off by the Myrio whenever the room has no presence of any persons. This human detection process is done by using PIR sensor. PIR (Passive Infrared) sensor is a motion detection sensor which is used for detecting the presence of any human by emitting Infrared light. So this sensor is used to find the presence of any human and turn ON or OFF the electrical appliances. For example: If a person is present in the room and the person left the room without turning OFF the fan and light, then this may cause the total power consumption to increase. So with the help of PIR sensor the presence of human is found and there is no on present in the room then all the electrical appliances like fan, light are turned OFF automatically and they are turned on if the person enters the room again. The Pushbutton is used to reset the whole home electrical appliances back to its previous state. The NodeMCU board is used to provide remote control for user to turn ON and OFF their electrical appliances. With help of Blynk app the user can remotely control their Electrical appliances.

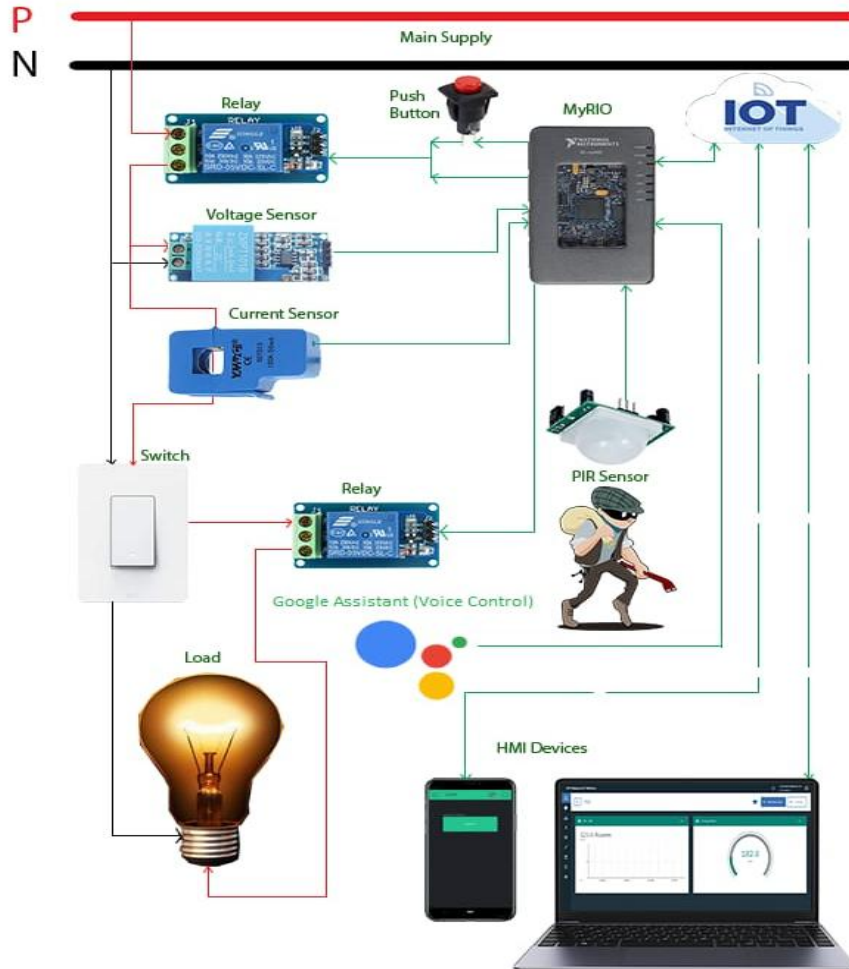

Figure: 4 Schematic diagram of the Home Automation system

The Intruder system is one that is used to safeguard our house from thief's and intruders. So when the owner of house is going out and after locking all the doors he turns ON the Theft system using the Blynk app. There will be a button present in the Blynk app, if it is turned ON then PIR sensor will be used to detect any persons in the house. If any persons are detected then an Alarm will be turned ON and a led will be turned ON in the Blynk app. The voice control of home appliances is done with the help of google assistant, IFTTT (If This Then That) platform, blynk app, Node MCU and relay. The working flow will be:

Google assistant --> IFTTT --> Blynk --> Node MCU --> Relay-->Home appliances

Relay: It is a device is used to turn OFF/ON the home appliances, the control can be done by a trigger which is sent from the Node MCU, It has two modes which are normally closed (NC) and normally open (NO), the normally closed mode is preferred for this project because the voice control has to be overridden by manual control also, for that the relay is connected after the switch control.

Node MCU: It is a microcontroller which has an in-built Wi-Fi module (ESP8266) by which it can be connected with the blynk IoT platform and control the relay.

Blynk: It is an open platform for IoT which is user-friendly, the cloud provided the blynk is faster So that the controlling and monitoring can be done efficiently and quickly.

IFTT: It is a platform used as the intermediate between google assistant and blynk by which the voice control can be achieved, the term If This Then will be google assistant and Thatwill be web hook in which the blynk IP address and the authentication token of the blynk project is given to it.

Google Assistant: Google Assistant is a virtual assistant, with artificial intelligence, developed by Google which can be used to understand and respond to the voice command given by the user.

VI. EXPERIMENTAL RESULTS WITH TABLE AND FIGURES

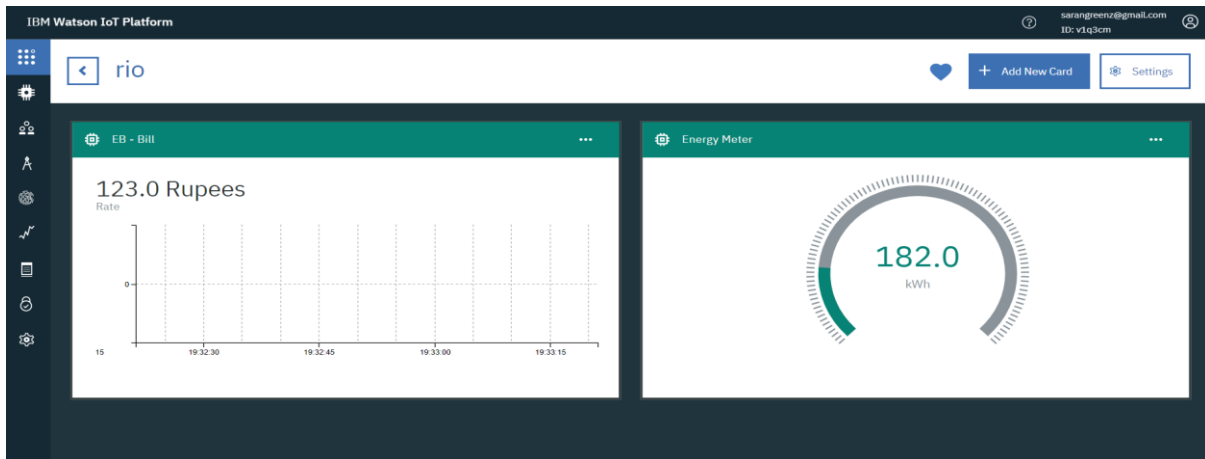

Figure: 4 Power consumed and estimated cost displayed in IBM IoT platform

This paper suggests a better and effective way to reduce the electricity bill by continuously monitoring the power consumed, its estimated cost and an alert system that sends the user notifications when the consumed power is about to reach the next slab. By implementing this method the user can know or view the power consumed and its cost wherever and whenever the user needs it with the help of IoT. The below figure shoes the overall setup of the system that consists of Myrio, Arduino, current and voltage sensor and its connection.

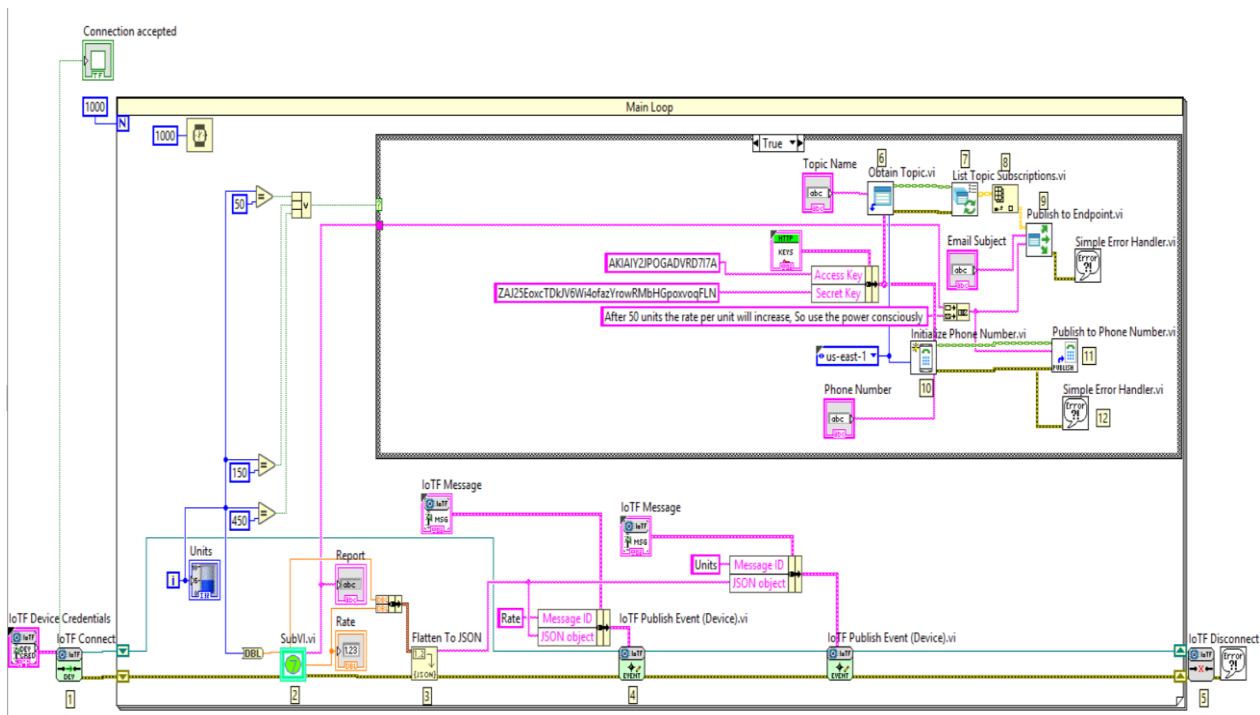

Figure: 5 LabVIEW code for Power consumption monitoring and alert system

All the solutions proposed in this paper is for reducing the total power consumed which in turn will also decrease the cost. So the user need not pay more money for the unnecessary power they use and also make their living easy by

automation through IoT. To access a cloud, the MQTT protocol is needed, It varies for every platform, In the above block diagram the functions numbered as 1, 4, 5 is used for IBM platform which is used for monitoring purpose, the functions numbered as 6, 7, 9, 10, 11 is used for SMS and E-Mail services by AWS(Amazon Web Services).

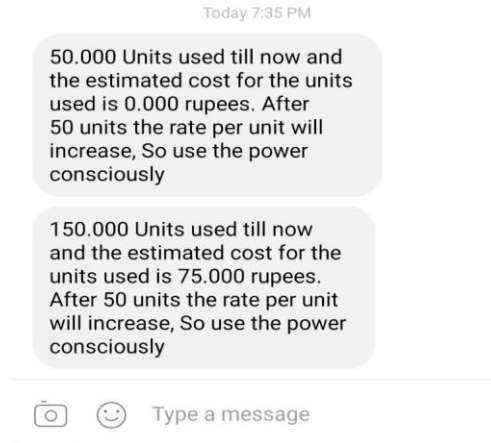

Figure: 6 Alert SMS

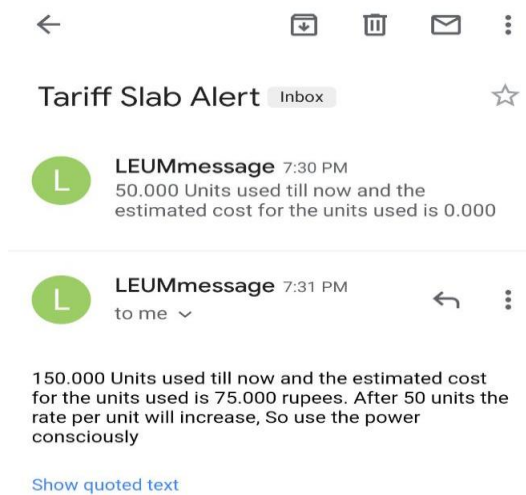

Figure: 7 E-mail Alert

The fig 5 represents the LabVIEW code for performing the power calculations and estimated cost for the power consumed using IBM and AWS IoT. The fig 6 and 7 shows the Alert SMS and E-mail sent to the user 50 units before reaching the next slab. So all these system are used for betterment of human life. Fig 8 and 9 shows the picture of controlling home appliances using Google Assistant.



Fig:8 voice control of light using Google assistant

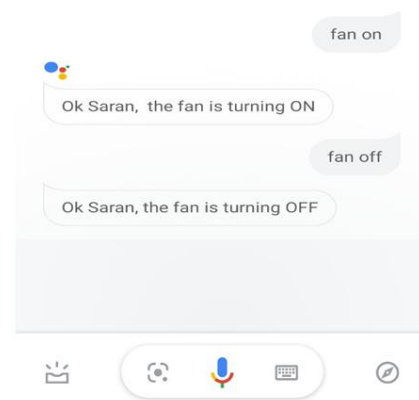

Fig:9 voice control of fan using Google assistant

VII. CONCLUSION

This paper suggests an idea to reduce power consumption in home by continuously monitoring the power consumed and allow the user to view the estimated cost for the usage. SMS and E-mail notifications are sent to the user as Alert messages so that the user may consume the power more carefully. The Automation and the Intruder alert system are done using the PIR sensor which helps in providing an easy, effective and a secure system for the house. Controlling of Home appliances using Google assistant also helps everyone in the ease by just giving voice commands rather than getting up from the seat to turn ON/OFF the appliances.

REFERENCES

- [1]. Elamvazuthi, M.K. A., Ahamed Khan, SyajiqBasri Bin Shaari, RajendranSinnadurai and M.Amudha, "Electrical Power Consumption Monitoring using a Real-time System", 2012 IEEE Conference on Sustainable Utilization and Development in Engineering and Technology (STUDENT) UniversitiTunku Abdul Rahman, Kuala Lumpur, Malaysia. 6 - 9 October 2012.
- [2]. Tsung-Yueh Wan, Chun-I Chiang, Chao-Tung Yang, Shuo-Tsung Chen, and Jung-Chun Liu,- "Implementation of an Energy Saving Cloud Infrastructure with Virtual Machine Power Usage Monitoring and Live Migration on OpenStack", 2016 IEEE 22nd International Conference on Parallel and Distributed Systems.
- [3]. I. Abubakar, S. N Khalid, M. W. Mustafa, Hussain Shareef and M. Mustapha, "Calibration of ZMPT101B Voltage Sensor Module Using Polynomial Regression for Accurate Load Monitoring", Vol. 12, NO. 4, February 2017 ARPN Journal of Engineering and Applied Sciences.
- [4]. C. Meetoo, S. Bahadoorsingh, N. Ramsamooj and C. Sharma, "Wireless residential power monitoring system", IEEE Manchester Power Tech, Manchester, 2017.
- [5]. ViorelMiron-Alexe, "IoT Power Consumption Monitoring System For Off-Grid Households", December 2017 IEEE.
- [6]. R. Bharathi, M. E. Madhushree, Priyanka Kumari, "Power Consumption Monitoring System using IoT", Volume 173 – No.5, September 2017 International Journal of Computer Applications.
- [7]. Antony Jerome, Ashra Ahmed Saied, RithikaBekal, Santhrupthi S. M., Rahul V. A. "AutoHome an NI MyRIO Based Project", International Journal of Internet of Things 2017, 6(2): 29-33.
- [8]. BibekKanti Barman, Shiv Nath Yadav, Shivam Kumar, SadhanGope "IOT Based Smart Energy Meter for Efficient Energy Utilization in Smart Grid" 2018 IEEE.
- [9]. Shu-ping Le, Hong Zeng, Jian Qiu, Song Zhang "Design and Implementation of Wireless Power Monitoring System for Public Buildings", International Conference on Electronic & Mechanical Engineering and Information Technology 2011.
- [10]. Pampa Sadhukhan, "An IoT based Framework for Smart City Services" 2018 IEEE.
- [11]. George Suci, Lucian Necula, RalucaLosu, TeodoraUsurelu, Marian Ceaparu "IoT and Cloud-Based Energy Monitoring and Simulation Platform" IEEE March 28-30, 2019.
- [12]. Khirod Chandra Sahoo, Umesh Chandra Pati "IoT Based Intrusion Detection System Using PIR Sensor" 2nd IEEE International Conference On Recent Trends in Electronics Information & Communication Technology (RTEICT), May 19-20, 2017
- [13]. S.Shakthidhar, P.Srikrishnan, S.Santhosh, M.K.Sandhya "Arduino and NodeMcu based Ingenious Household Objects Monitoring and Control Environment" Fifth International Conference on Science Technology Engineering and Mathematics (ICONSTEM) 2019
- [14]. Deepta Mukherjee, Sujoy Kundu, TapasundarKar, AnirbanChakraborty "Controlling multiple Home appliances through Google assistant and monitoring sensor's data from server" IEEE