

# Study of Thermal Performance Between Circular Fin, Triangular Fin and Plate Fin Heat Sinks Under Natural Convection

**Vaibhav Kumar<sup>1</sup>, Shamsul Haq<sup>2</sup>**

M. Tech Scholar, Department of Mechanical Engineering, Patel College of Science and Technology, Bhopal<sup>1</sup>

Associate Professor, Department of Mechanical Engineering, Patel College of Science and Technology, Bhopal<sup>2</sup>

**Abstract:** Thermal performances of circular-fin, triangular fin and plate fin heat sink with horizontal base plate were compared in natural convection. Comparison is performed with same base plate dimensions and height of fin condition and same power input. In the work herein, steady-state natural convection heat transfer and thermal performance comparison between circular finned heat sink, triangular finned heat sink & plate finned heat sink from horizontally-oriented base plate is investigated. SOLIDWORKS software is used in order to develop a three-dimensional numerical model for investigation of different fin geometries effects. Results show that an alteration in fin geometry and material of the fins enhances the thermal performance of fins and reduces the weight of the fin arrays, which leads to lower manufacturing costs. The optimum spacing for maximum fin array thermal performance is found. This study suggests that the most important geometric parameter influencing the heat transfer from fin is the height of fin & also the material of the fins.

**Keywords:** Fin Spacing, Fin Geometries, Temperature Distribution, Height, Length, Heat Transfer Rate.

## I. INTRODUCTION

Currently, many industries face trouble of overheating in digital factors due to warmth technology inside them. The industries manufacture the home equipment with compact design and low cost. But the warmth wants to be disbursed at greater fee to preserve the temperature of the system so that the aspect stays inside working temperature range. Therefore, devising environment friendly cooling is a reply to fulfil cooling requirement in devices. To overcome the problem of overheating, especially in thermal systems, fins are typically provided. In the Universe, all device or substance undergoes the manner of warmth switch in order to make the machine in equilibrium. It takes place due to distinction in temperatures in the substance. This temperature distinction acts as a feasible pressure to switch warmth from one vicinity to another. But the price of warmth switch relies upon on a variety of elements like media surrounded by means of the substance, the fabric used to produce the substance, temperature distinction in the substance, pressure utilized (if any) to manifest warmth switch in the substance etc.

Danish Ansari et al [1] numerically investigated and in contrast Hotspot thermal manage the utilization of a micro channel pin-fin amalgamation heat sink. Erfan Rasouli et al [2] experimentally studied and sundry several pitch and issue ratios of eight micro pin-fin warmth sink characterised underneath Neath single-section liquid waft and moreover investigated their warmth change and stress drop at some stage in the pin-fins. Sanchai Ramphueip had et al. [3] The junction temperature and fan pumping electrical energy of the warmth sink have been optimized and experimentally investigated on multi goal optimization of a multi cross-segment pin fin warmth sink (MCSPFHS) utilized in digital devices. Xiangrui Meng et al. [4] The influence of mounting component on warmth dissipation standard overall achievement of a warmth sink below herbal convection situation is researched on this paper thru numerical simulation and experimental tests. Z.G Liu et al. [5] experimentally proved that pin-fin shape significantly affects warmth swap at large Reynolds number. Hongxia Zhao et al. [6] experimentally investigated with particular fashions and shapes that triangular pin-fins have massive waft resistance and elliptical pin-fin has greater streamline with limit thermal resistance. Weilin Qu et al. [7] on this paper, the roughness viscosity model and viscosity model had been proposed to interpret experimental records and analysed the penalties the usage of three-dimensional conjugate variations numerically over the micro channel warmth sink. R. Sajedi et al. [8] the numerical lookup grow to be performed for questioning about the effect of a splitter at the hydrothermal habits of a pin-fin sink, frequently growing the warmth change region to attain the foremost rate of warmth losses in a very constrained region to stay removed from or weaken the glide separation and bargain of the strain drop through the warmth sink.

**II. EXTENDED SURFACES (FINS)**

The prolonged surfaces referred to as fins are basically used in the fields of automobiles, digital components, electrical motors etc., to enlarge warmness switch rate, to make bigger the lifestyles and effectively of the device. The warmness switch from one region to some other location takes place by means of three mechanisms, specifically Conduction, Convection and Radiation.

Convection warmness switch between a warm stable floor and consequently the surrounding less warm fluid is given by Newton. According to Newton's law of "the charge of convection warmness switch is at once proportional to the temperature distinction between the current floor, and the surrounding fluid and is moreover without delay proportional to the world of contact or publicity between them".

$$Q_{conv} = h A (T_s - T_{\infty})$$

Where,  $h$  = convection heat transfer coefficient

$T_s$  = Hot surface temperature

$T_{\infty}$  = Fluid temperature

$A$  = area of contact or exposure

Therefore, convection heat transfer are often increased by either of the subsequent ways

Therefore, convection warmth switch are frequently accelerated via both of the subsequent ways

1. Either through growing the temperature distinction between the floor and consequently the fluid.
2. By developing the convection warmth switch coefficient by means of enhancing the fluid float or float speed over the body.
3. Increasing the place of contact or publicity between the floor and consequently the fluid.

**Advantages & Disadvantages of Fins**

Fins proved to be most environment friendly way of bettering warmness switch from any floor uncovered to fluid nearby. They grant heavy responsibility besides any everyday upkeep without they supply financial and less expensive thanks to amplify the velocity of warmness switch and funky down the floor from which warmth is to be extracted. With benefits there are some few negative aspects too, attaching fins to any floor will increase the weight and can also every so often limit the normal efficiency. They are frequently used solely the place a floor is in direct contact with the fluid close by.

**Application**

Fins are extensively used for the application of enhancing and increasing the rate heat transfer from the surface. Their applications are in wide range. Some of the applications are mentioned as, they used in the form of arrays for cooling down electronic equipment's. They are used in IC engines where engine is exposed directly to air like two wheelers and air crafts. They are used in compressors as well. Fins are also used in the evaporator and condensation components of the refrigeration and air conditioning. Besides they are used in dry type cooling towers, condensers and economizers of thermal power plant.

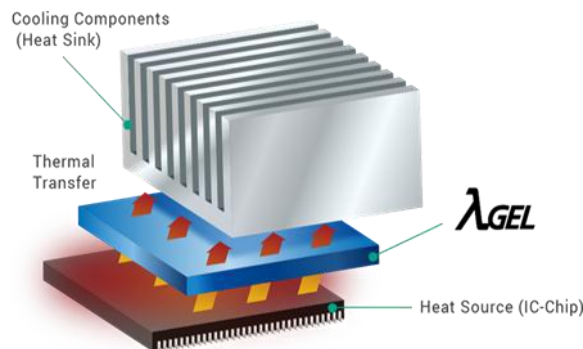

Fig.1 Fins on the surface of electronic devices

**III. OBJECTIVES**

In the present work main objectives are:

(a) To develop structural modeling of heat sink & fins by using SOILDWORKS software. The model saved in. SLDPRT file format and further analysis carried in SOLIDWORKS software.

(b) Thermal analysis of heat sink along with fins using SOLIDWORKS software.

(c) Comparison between existing Aluminum alloy & Copper alloy fins in terms of temperature difference

Different shapes of fins are used for the same purpose. Mainly circular fin, triangular fin & plate fin are used. The main aim of this work is to find minimum temperature or maximum heat transfer for above shape of fins and select the better design which can enhance the heat transfer.

**IV. MATERIAL PROPERTIES**

Material used for selected fins is 1060 Aluminium alloy and Aluminium Bronze (Copper Alloy), the properties of the material are presented in the Table

Table I: Material Properties of Aluminium Alloy (1060 Alloy)

Fins Material	1060 Alloy
Heat of Fusion	390 J/g
Specific Heat Capacity	0.900 J/g-°C
Thermal Conductivity	200 W/m-K
Melting Point	646.1 - 657.2 °C
Elastic modulus	69 GPa
Yield strength	28 MPa
Density	2700 kg/m <sup>3</sup>
Behaviour	Linear Elastic Isotropic

Table II: Material Properties Of Copper Alloy (Aluminium Bronze)

Fins Material	Aluminium Bronze (Copper Alloy)
Heat of Fusion	390 J/g
Specific Heat Capacity	0.380 J/g-°C
Thermal Conductivity	56 W/m-K
Melting Point	1047 °C
Elastic modulus	117 GPa
Yield strength	380 MPa
Density	7400 kg/m <sup>3</sup>
Behaviour	Linear Elastic Isotropic

**V. BOUNDARY CONDITIONS**

Boundary conditions are the collections of different heat power supply, temperature, constraints and any other conditions required for complete analysis.

Here heat power of 50 W is supplied to the base of the heat sink and all the faces are exposed to air having heat transfer coefficient of 25W/(m<sup>2</sup>-k). In the present study, ambient temperature is assumed to be 25°C. The boundary conditions are indicated in fig 2

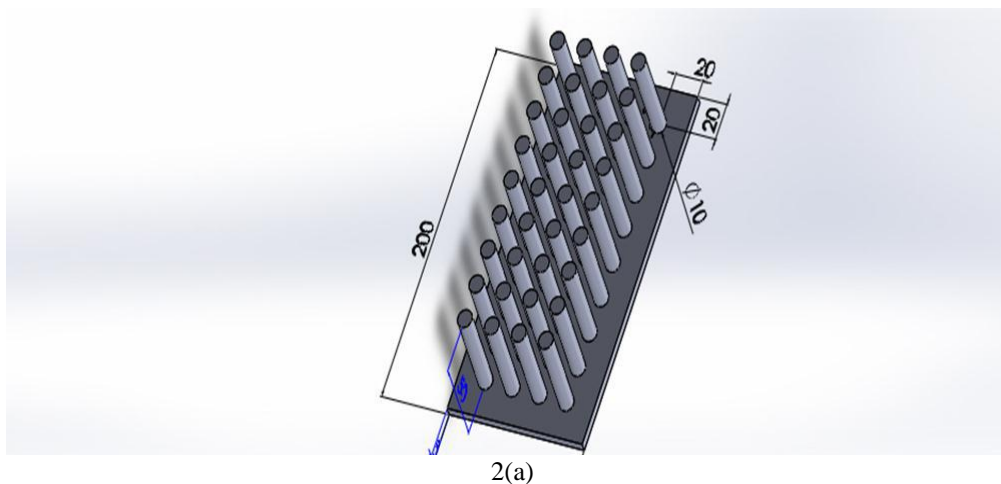

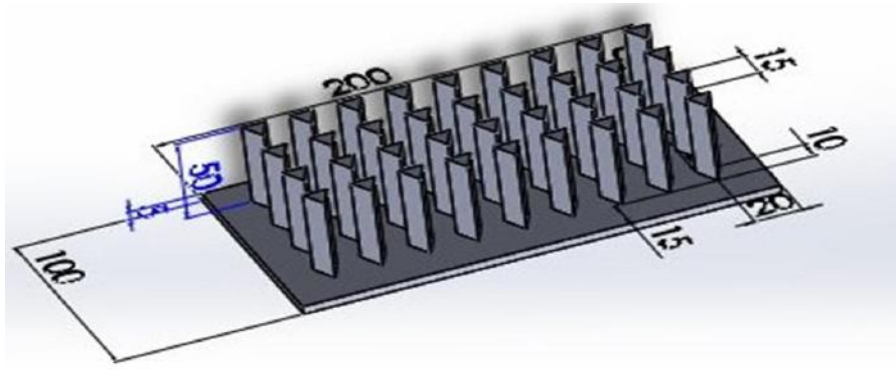

2(b)

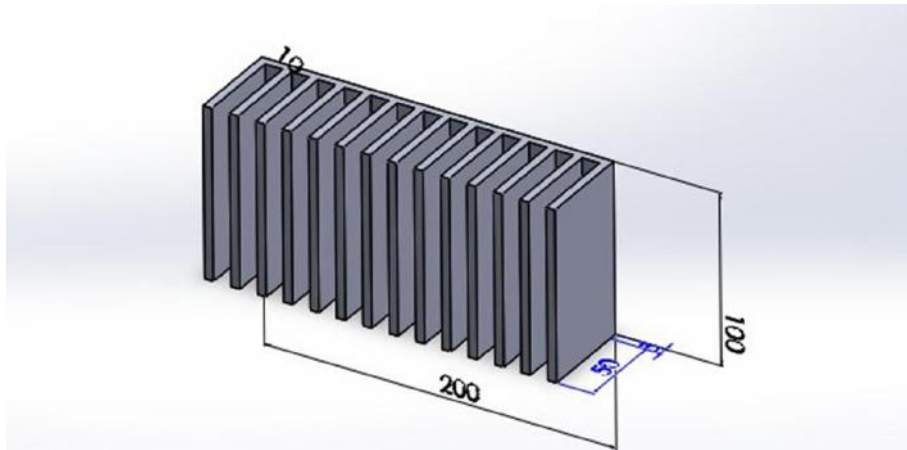

2(c)

Fig.2 (a) (b) (c) Geometry modelling for circular fin, triangular fin and plate fin heat sink on SOLIDWORKS Software.

### VI. MESHING

Meshing of geometries is done on SOLIDWORKS software under meshing setup.

#### (a) Mesh Information for Circular Fins

Element Size	6.31027 mm
Total Nodes	19912
Total Elements	9763

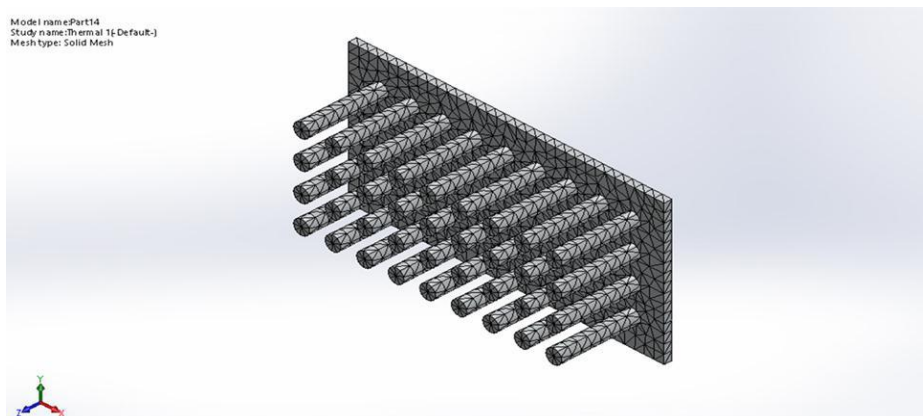

Fig.3 Meshed Model of Heat Sink with Circular pin fins

**(b) Mesh Information for Triangular Pin Fins**

Element Size	6.36394 mm
Total Nodes	16258
Total Elements	7430

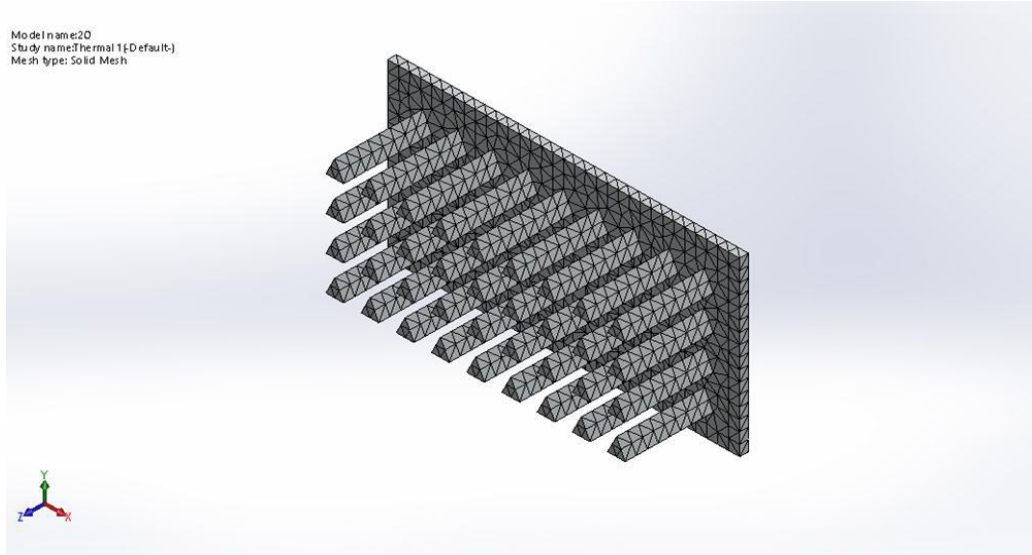

Fig.4 Meshed Model of Heat Sink with Triangular pin fins

**(c) Mesh Information for Plate Fins**

Element Size	8.7178 mm
Total Nodes	20843
Total Elements	11186

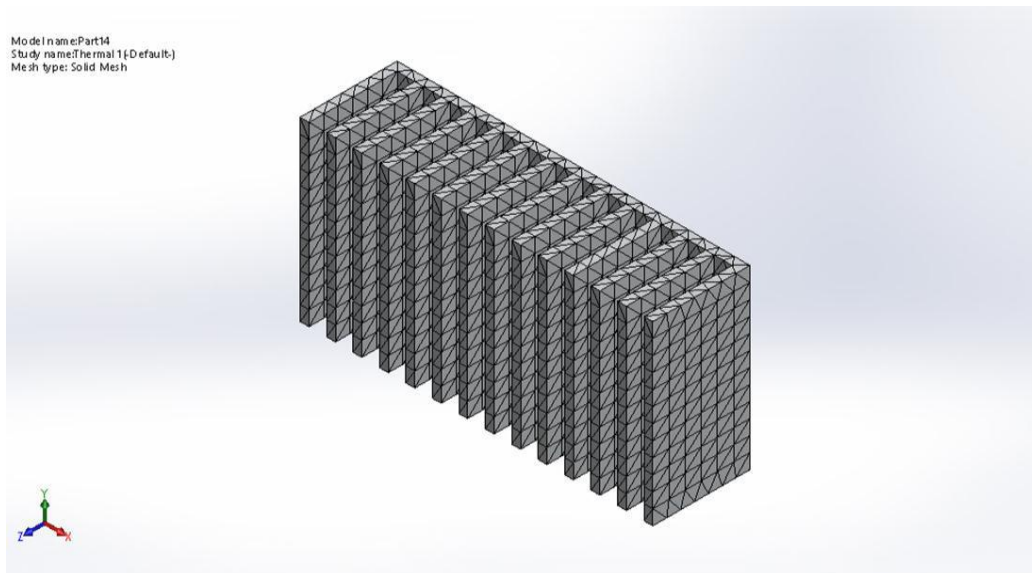

Fig.5 Meshed Model of Heat Sink with Plate fins

**VII. RESULT AND OBSERVATIONS**

Thermal analysis has been performed to evaluate various types of heat sinks designs with copper and aluminium as materials in natural convection conditions. Results obtained in thermal analysis are presented below. We can clearly observe that the heat transfer rate is directly proportional to temperature gradient ( $\Delta T$ ).

### ➤ Temperature distribution analysis of Fins Models

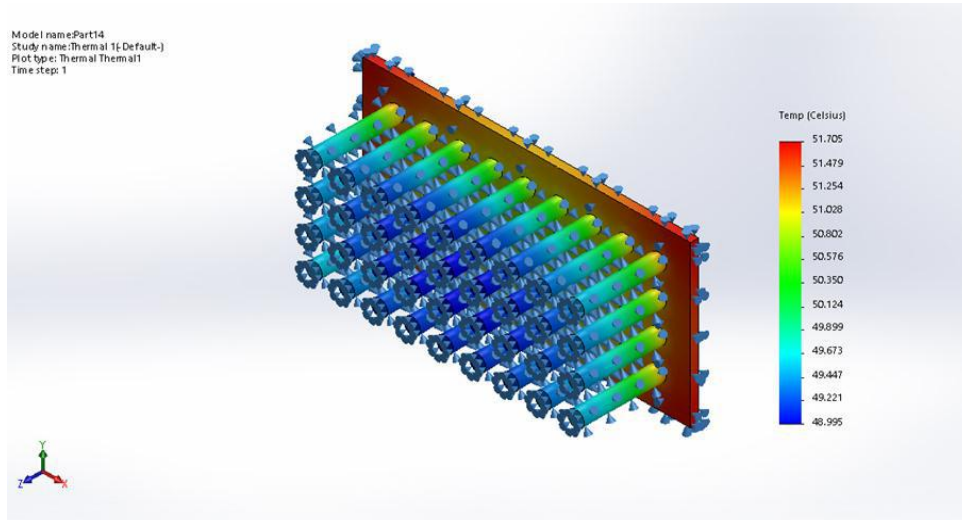

Fig.6 Temperature distribution on array of circular pin fins (Aluminium Alloy)

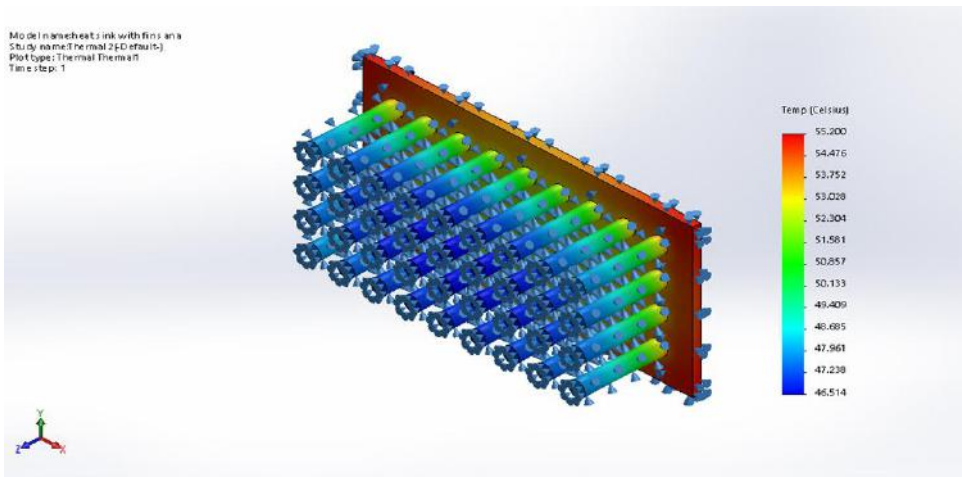

Fig.7 Temperature distribution on inline array of circular pin fins (Copper Alloy)

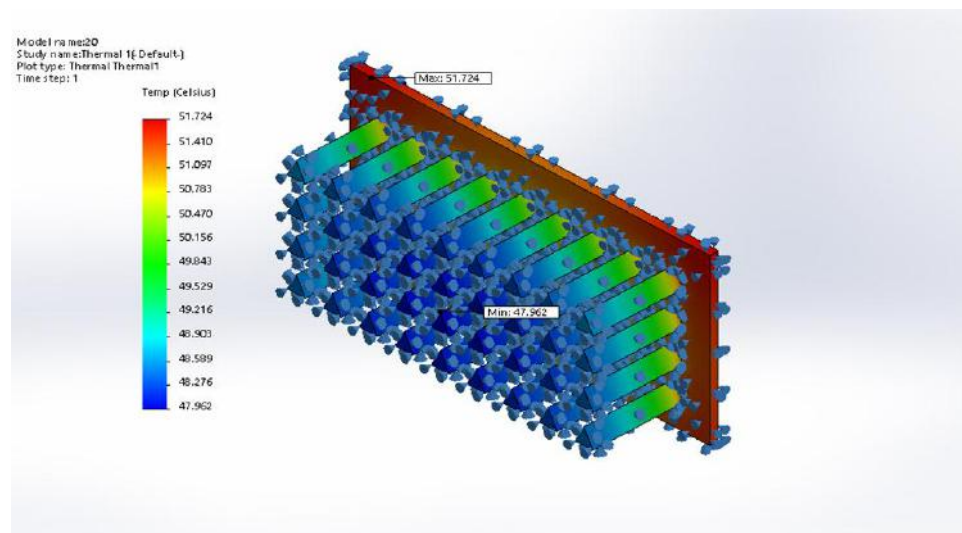

Fig.8 Temperature distribution on inline array of triangular fin heat sink (Aluminium Alloy)

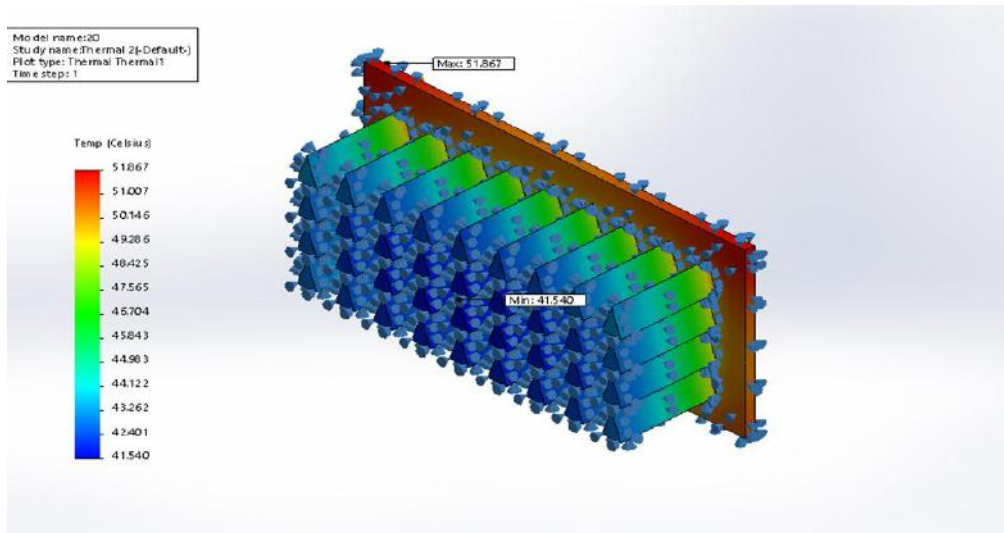

Fig.9 Temperature distribution on inline array of triangular fin heat sink (Copper Alloy)

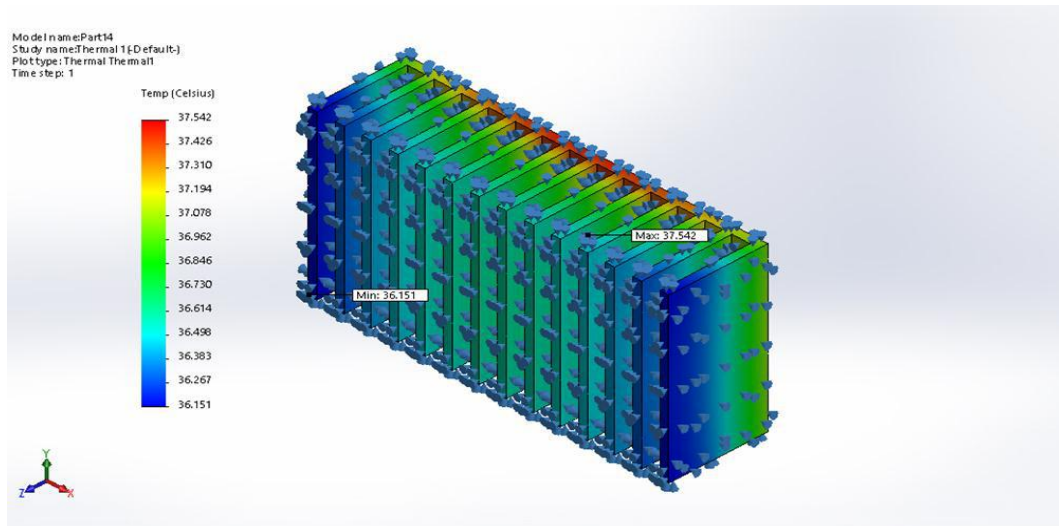

Fig.10 Temperature distribution on inline array of Plate Fin heat sink (Aluminium Alloy)

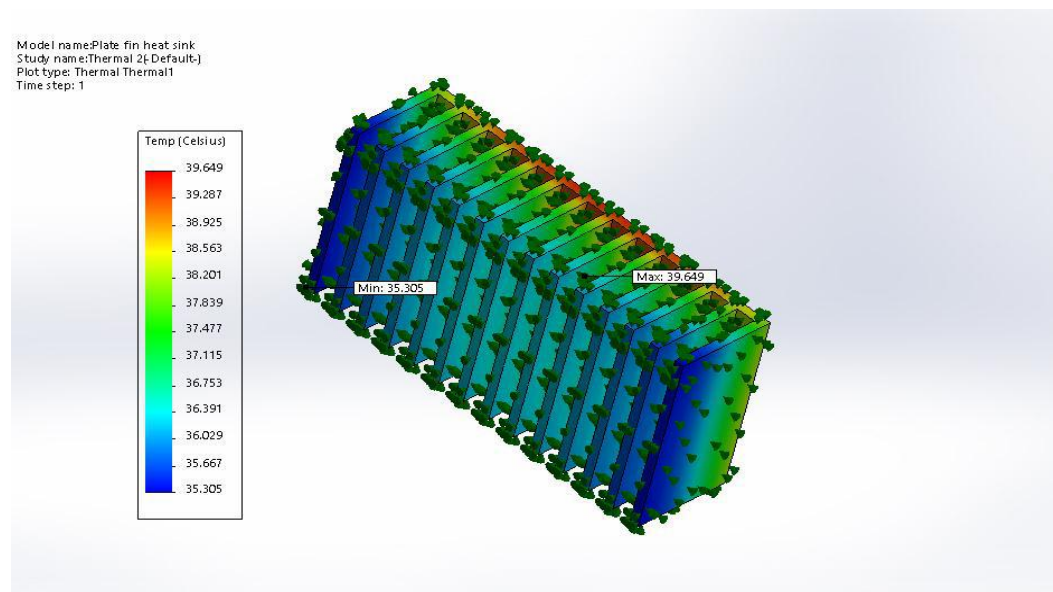

Fig.11 Temperature distribution on inline array of Plate fin heat sink (For Copper Alloy)

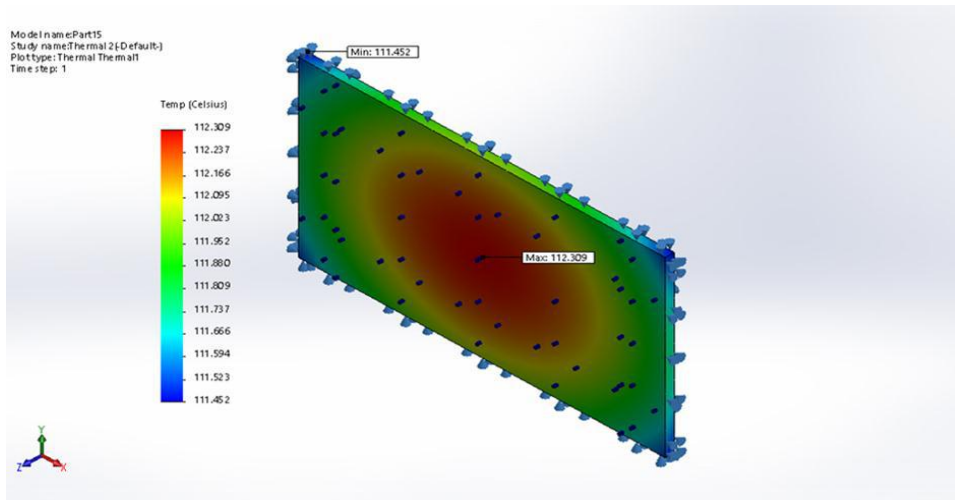

Fig.12 Temperature distribution on base plate without Plate fin (For Aluminium Alloy)

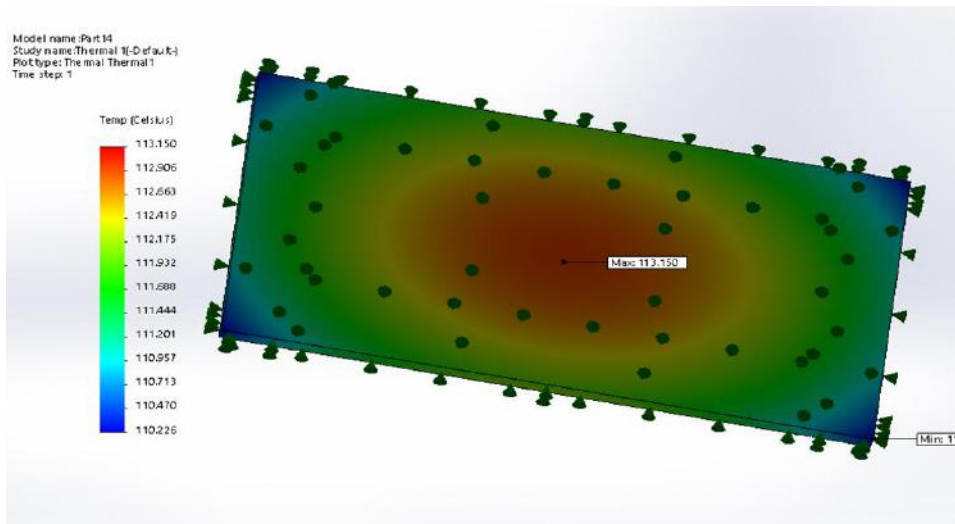

Fig.13 Temperature distribution on base plate without array of Plate fin (For Copper Alloy)

Table III: Shows the Maximum and Minimum temperature variations

Geometry Condition	Max Temperature (°C)	Min Temperature (°C)	Total Temperature drop (°C)
Base Plate without Fins (Al)	112.309	111.452	0.857
Base Plate without fins (Cu)	113.150	110.126	3.024
Circular Pin Fins (Al)	51.7053	48.9951	2.7102
Circular Pin Fins (Cu)	55.2	46.514	8.686
Triangular Pin Fins (Al)	51.724	47.962	3.765
Triangular Pin Fins (Cu)	51.867	41.540	10.327
Plate Fins (Al)	37.542	36.151	1.391
Plate Fins Cu)	39.649	35.305	4.344

## VII. CONCLUSION

Based on the study of thermal performance of different type of fin having different geometry and materials following conclusions can be drawn:

Thermal performances circular pin, triangular pin fin & plate fin heat sinks were compared for fixed base plate dimensions, fin height, same power input & different material. From the comparative analysis it is found that maximum temperature drop is found in triangular pin fins made up of copper alloy. So, it can be concluded that fins with triangular pin fin shows better heat transfer properties. Fins with triangular profile include much less material and are extra



environment friendly than the ones with rectangular profiles, and for that reason are more appropriate for functions requiring minimal weight such as space applications.

From the optimization it is found that length or height of the fin play a vital role in heat transfer. A vital consideration in the plan of finned surfaces is the determination of the applicable fin size  $L$ . Normally the longer the fin, the larger the heat switch region and consequently the greater the price of warmth switch from the fin, but additionally the larger the fin, the better the mass, the greater the price, and the larger the fluid friction. Therefore, growing the size of the fin past a certain price can't be justified except the delivered advantages outweigh the added cost. Also, the fin efficiency decreases with growing fin length because of the limit in fin temperature with length. Fin lengths that cause the fin efficiency to drop beneath 60 % normally can't be justified economically and must be avoided. The efficiency of most fins used in practice is above 90%. The analysis has been done using SOILDWORKS which uses Finite Element method for Analysis.

### VIII. FUTURE SCOPE

Many operating and design parameter have been covered in this research. However there are many other issues that may be investigated. Recommended future studies as follows,

- (i) There may exist other designs which produce better results in overall thermal performance.
- (ii) Fins with parabolic contain less material and are more efficient requiring minimum weight will be the better option as compared to other.
- (ii) A study looking at reduced spacing, pin alignment, pin staggering, and an array of ellipse axis ratios would be advantageous to the heat sink industry
- (iv) Size, aspect ratio, orientation and number of fins on a heat sink with fins has to be optimized further to improve the performance. Metal 3D printing of heat sinks can be considered and design can be further optimized where even complex profiles can be manufactured.

### REFERENCES

- [1]. Ansari, D., & Kim, K. Y. (2018). Hotspot thermal management using a micro channel-pin fin hybrid heat sink. *International Journal of Thermal Sciences*, 134, 27-39.
- [2]. Rasouli, E., Naderi, C., & Narayanan, V. (2018). Pitch and aspect ratio effects on single-phase heat transfer through microscale pin fin heat sinks. *International Journal of Heat and Mass Transfer*, 118, 416-428.
- [3]. Ramphueiphad, S., & Bureerat, S. (2018). Synthesis of multiple cross-section pin fin heat sinks using multi objective evolutionary algorithms. *International Journal of Heat and Mass Transfer*, 118, 462-470.
- [4]. Meng, X., Zhu, J., Wei, X., & Yan, Y. (2018). Natural convection heat transfer of a straight-fin heat sink. *International Journal of Heat and Mass Transfer*, 123, 561-568.
- [5]. Liu, Z. G., Guan, N., Zhang, C. W., & Jiang, G. L. (2015). The flow resistance and heat transfer characteristics of micro pin-fins with different cross-sectional shapes. *Nano scale and Micro scale Thermo physical Engineering*, 19(3), 221-243. *Technology, Part A, IEEE Transactions on*, 18 (1995) 559-566.
- [6]. Zhao, H., Liu, Z., Zhang, C., Guan, N., & Zhao, H. (2016). Pressure drop and friction factor of a rectangular channel with staggered mini pin fins of different shapes. *Experimental Thermal and fluid science*, 71, 57-69.
- [7]. Qu, W., Mala, G. M., & Li, D. (2000). Heat transfer for water flow in trapezoidal silicon micro channels. *International Journal of Heat and Mass Transfer*, 43(21), 3925-3936.
- [8]. Sajedi, R., Osanloo, B., Talati, F., & Taghilou, M. (2016). Splitter plate application on the circular and square pinfin heat sinks. *Microelectronics Reliability*, 62, 91-101.
- [9]. Fundamentals of Engineering Heat and Mass transfer by R C Sachdeva
- [10]. Heat and Mass transfer by R K Rajput
- [11]. NPTEL notes