

# RADIO FREQUENCY IDENTIFICATION (RFID) BASED ATTENDANCE SYSTEM WITH SHORT MESSAGE SERVICE (SMS) BACKUP

**B. Arthi<sup>1</sup>, R. Virudhiga<sup>2</sup> and Mr. E. Rajasekaran<sup>3</sup>**

UG Scholar, Department of Electrical and Electronics Engineering,  
Krishnasamy College of Engineering and Technology, Cuddalore<sup>1,2</sup>

Assistant Professor, Department of Electrical and Electronics Engineering,  
Krishnasamy College of Engineering and Technology, Cuddalore<sup>3</sup>

**Abstract:** This proposed work deals with automatically registering students, recording attendance, saving students' data on the Personal Computer (PC) as well as backing this data via the Global System for Mobile communication (GSM) and finally making a decision on the eligibility of a student to sit for an examination course. Owing to the challenges of the manual method of taking attendance in colleges, an automated attendance system needs to be adopted. The challenges include difficulty in keeping the attendance list over a long period of time, unnecessary time wastage during writing and signing attendance, improper documentation, students forgetting to write or sign the attendance paper, lecturers forgetting the attendance list in the classroom, students writing or signing illegally for an absentee amongst others. A modular approach was utilized in the design.

**Keywords:** RFID, GSM, Atmega 328p.

## INTRODUCTION

Students are expected to attend 70 percent of a lecture class before they are allowed to sit for an examination as directed by the Nigerian Universities' Commission (NUC) policy. The manual method of taking attendance in universities and colleges in Nigeria over the years has become a thing of concern. In the manual method of taking attendance, students are required to write down their names and sign an attendance list. The problems associated with the manual method of taking attendance vary from unnecessary time wastage to improper documentation, students forgetting to put down their names on the attendance list or students writing on behalf of other students that are absent from the class [10]. To eradicate the deficiencies associated with the manual attendance system, an automated approach is implemented using the RFID technology. The design incorporates an RFID reader, RFID tags, computer system, mobile devices, and host system application. The design ensures that student's attendance is taken automatically as well sending short message to the student mobile phones which serves as a means of alternative backup in the case of data loss by the lecturer and also serves as a means of giving warning to students in cases of low attendance which could degrade their performance or prevent them from taking the course examination, if the class attendance percentage is less than 70.

The need for the application of RFID technology to student class attendance in this proposition will lead to elimination or reduction of the quality time wasted during manual collection of attendance. The need will also lead to the creation of a student database management system that is not prone to errors or being manipulated by anyone and above all aids in better management of classroom statistics for participation in examination and allocation of attendance scores in the final grading of student performance in a particular course. A number of related works pertaining to the application of RFID and GSM Technology to different areas and specifically to the area of attendance monitoring exists.

Designed and implemented RFID Based Exam Hall Maintenance System which resolves the problem of students searching for their examination halls and seating arrangements. The card reader is provided at the entrance of the building. A student needs to swipe his tag in front of the reader at any hall and his hall and seat number would be displayed on the LCD. Designed and implemented the application of RFID Technology in Libraries termed RFID based library management which saves the library staff's time and energy by automating their task. Borrowing and returning of books are automated using the check-in, check-out system which is RFID based. The limitation of the system is that it is costly to implement. Propose an automatic attendance system using fingerprint verification technique. The fingerprint technique verification was achieved using extraction of abnormal point on the ridge of user's fingerprint or minutiae technique. The verification confirms the authenticity of an authorized user by

performing one to one comparison of a captured fingerprint templates against the stored templates in the database. The proposed automatic attendance system signals either true or false based on logical result of previous one to one verification of person’s authenticity. However, the various researches conducted so far on the RFID attendance system does not incorporate a backup system. In a situation where there is loss of data on the PC due to system crash or malfunction.

In this work, we developed a graphical user interface (GUI) using Visual Basic 6 that will integrate an RFID system to capture and record student attendance with a backup SMS.

**MATERIALS AND METHOD**

This project is divided into software and hardware development. The software developmental program used for interfacing RFID to Arduino (ATMEGA 328P) microcontroller can simply be divided into four parts: Configuring the serial communication, reading the RFID card, fetching it from the memory location and displaying it on the LCD which is executed using C language. The hardware comprises of four main units: Power Supply Unit, Input Unit (RFID Tag and Reader), Control Unit (ATMEGA 328P Arduino Microcontroller and GSM Module), and the Output Unit (PC, LCD, and GSM). When the system is powered, the RFID reader starts monitoring and sensing for any scanned card within its electromagnetic region. When a card is scanned near the reader, the reader will decode the details (card number) of the card and sends the information to the central ATMEGA 328P Microcontroller for processing. The microcontroller processes and decodes the card number to ascertain if it is a valid one. If it is valid, access will be granted, and it displays the Student Name and Registration Number on LCD. The microcontroller also sends a signal to the Sim900 GSM module which then sends short message (SMS) notification containing students name, Reg. number, department, card number, etc., to a designated/student phone. This serves as data backup. The microcontroller will also send the details of the card and the number of times the card has been scanned to the PC database. This information can be accessed at any time using programmed staff tags which is designated to the lecturers to access the student attendance.

Table 1: Design materials

S/N	DESCRIPTION
1	16x2 Liquid Crystal Display (LCD)
2	SIM900 GSM Module
3	RC522 Radio Frequency Identification Module (RDIF Reader)
4	Radio Frequency Identification Tag (RDIF Tag)
5	Arduino Uno module
6	Transformer (2000mA, 240/15V)
7	SIM Card
8	Light Emitting Diode (LED)
9	IC Voltage Regulators
10	ATMEGA 328P Microcontroller
11	1000µf Capacitor
12	1kΩ Resistor
13	Bridge Rectifier (IN4001 power)
14	Connecting Wires
15	Connecting Wire Socket
16	Vero Board
17	A-B USB Cable
18	2.5mm <sup>2</sup> Cable
19	13A Fuse Plug

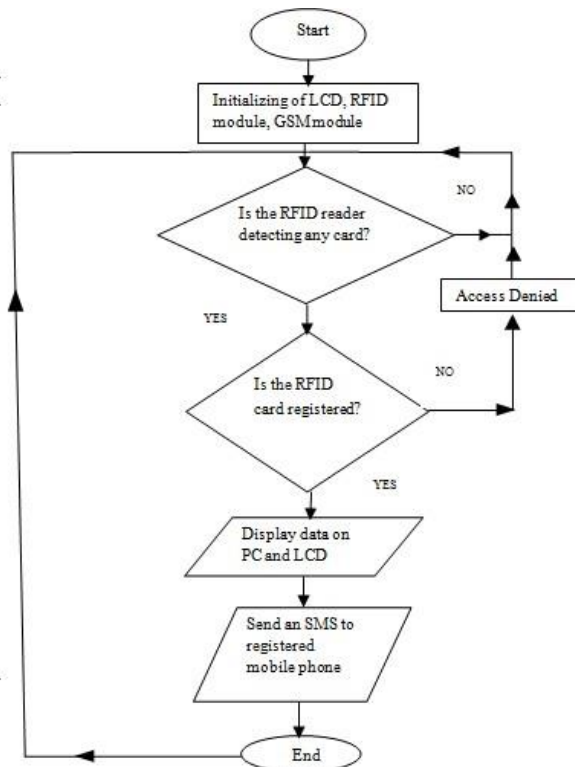

FIGURE 1: DESIGN FLOW CHAT

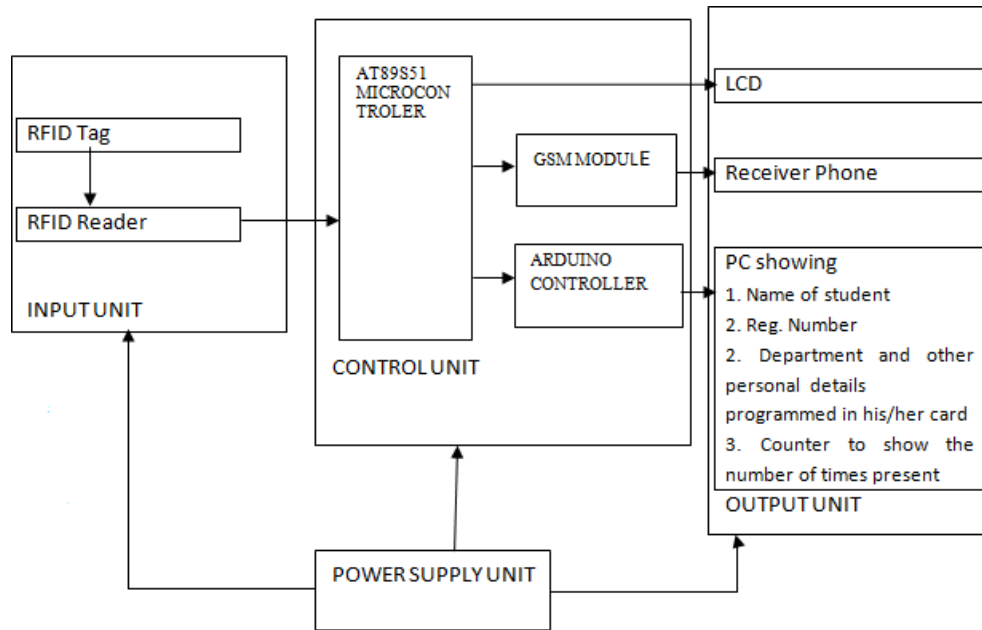
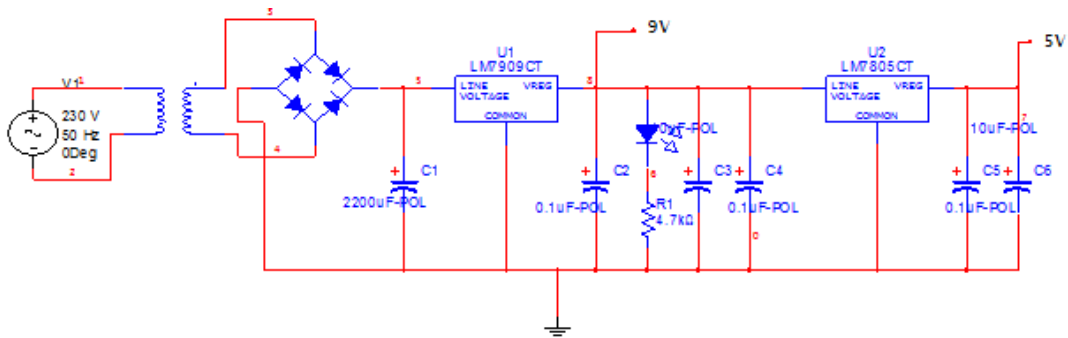

FIGURE 2: BLOCK DIAGRAM OF THE SYSTEM



BusOffPage1

BusOffPage2

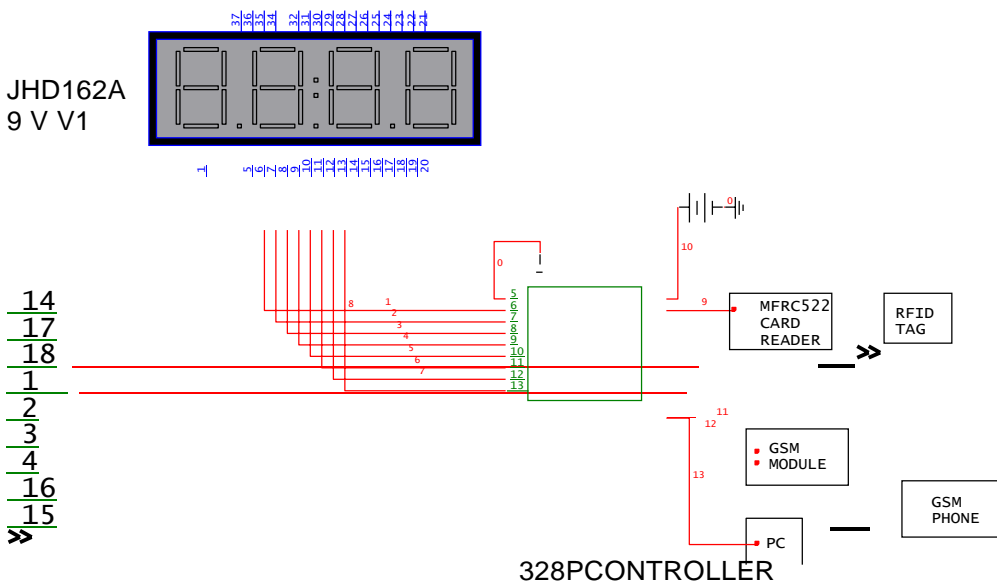

FIGURE 3: CIRCUIT DIAGRAM OF RFID BASED ATTENDANCE SYSTEM WITH SMS BACK UP

**TEST AND RESULTS**

After constructing the overall system circuit, the various segments were tested for appropriate functioning as shown below

This has to do with powering and testing the RFID Card of each student, the RFID reader and the LCD segment. When the system is powered, it displays “Swipe your RFID CARD”, meaning that the system is ready to scan card as shown below in plate 1.

When the card is swiped across the RFID reader, the reader will sense it, decode the embedded code (information) on it and sends the decoded signal to the central microcontroller (ATMEGA 328P Arduino) to process, if found valid, the code (Student Name and Registration Number) will be display on the LCD screen as shown below in plate 2.

**Figure 4: PROJECT KIT****CONCLUSION**

We have developed an RFID based student attendance system with short message service (SMS) notification backup which is helpful in saving valuable time of both students and lecturers and helps to generate accurate reports when required. The SMS feature serves as a backup if data loss occurs on the PC. For future work, we recommend incorporating a facial recognition application that would serve to further increase the biometric security of the system against impersonation by erring students. Also, we recommend including a timing circuit in order to specify the exact time/date each student enters the classroom so that erring students that use the card twice at the same time without the consent of the lecturer can be dictated.

**REFERENCES**

- [1]. C. Bardaki, P. Kourouthanassis and K. Pramatri. Deploying RFID-Enabled Services in the Retail Supply Chain, Lessons Learned toward the Internet of Things. *Information Systems Management*, 29(3), 233-245, 2012.
- [2]. S. Chitresh and K. Amit. An efficient Automatic Attendance Using Fingerprint Verification Technique, *International Journal on Computer Science and Engineering (IJCSSE)*, 2(2), 264-269, 2010.
- [3]. A. T. Dawes. Is RFID Right for Your Library, *Journal of Access Services*, 2(4), 7-13, 2004.