



Automatic Movable Smart Road Divider Using IOT

Sowjanya K N¹, Nikhil Jamadagni H M², K Unnimaya³, Bhavana G⁴, Dr.B Sudarshan⁵

Student, Dept. of Electronics and Communication, KS Institute of Technology, Bangalore, Karnataka^{1,2,3,4}

Professor, Dept. of Electronics and Communication, KS Institute of Technology, Bangalore, Karnataka⁵

Abstract: “This paper presents Smart Movable Road Divider for controlling the traffic congestion in metropolitan cities and to provide a free path for the ambulance. The work presented in this paper focuses on reducing the latency in traffic and free path for ambulance. The existing Road Dividers consists of equal number of lanes. Usually, in morning and evening peak hours the opposite side of the Road Divider is generally underutilized. To overcome this, Smart Movable Road Divider is implemented where the divider is moved based on the density of the traffic using IR Sensors. If the density of the traffic is high on one side, the divider is moved to the other side. Then the density of traffic is stored in cloud which is possible through IoT. A free path for Ambulance is provided using RF Module by controlling the traffic signal. A Prototype is developed and tested for the Congestion control which also works on safety measures by intimating the drivers about the movement of the Divider.

I. INTRODUCTION

In recent years, with an ever-increasing rate of development in metro cities around the world, there has been proportional increase in numbers of automobiles on the roads. Although the number of vehicles using the roads has increased, the static road infrastructure is almost the same and is unable to cope with changes like congestion, unpredictable travel-time delays and road-accidents that are taking a serious shape. Traffic congestion has been one of the major concerns faced by the metropolitan cities today in spite of measures being taken to mitigate and reduce it. It has emerged as one of the main challenges for developers in urban areas for planning of sustainable cities. In developing countries, like India, traffic is inherently chaotic and noisy. Identification of magnitude of traffic congestion is an essential requirement for defining the congestion and finding appropriate measures. The main focus of this paper is aimed at understanding the recurring urban congestion, its measurement, precautionary measure and suggests a remedial measure for the same. The implication of widening existing roads or building new ones will only results in additional traffic that continues to rise until peak congestion returns to the previous level. The total available space within the city for the construction of roads, railways and other transportation is restricted.

The paper discusses implementation of movable traffic dividers as congestion release strategy for metropolitan areas instead of traditional solution of widening the roads. The moveable traffic divider helps in their configuration of road capacity, so as to attain optimum benefit from roadway usage on the existing road. The problem with Static Road Dividers is that the number of lanes on either side of the road is fixed. Since the resources are limited and population as well as number of cars per family is increasing, there is significant increase in number of cars on roads. This calls for better utilization of existing resources like number of lanes available. The main aim of this project is to take the traffic controlling to a new era. The purpose of the project is to decrease the time of journey in the peak hours and to avoid traffic congestions and to provide a better and a smarter solution for the above said traffic problems. We design a movable road divider which moves depending on the flow of traffic. The IoT compiles the real-time data of vehicular traffic that finds out the current traffic operation and traffic flow conditions.

The IoT will be connected with each and every part of traffic such as roads, dividers with the help of infrared sensors. In many situations we see that there will be huge traffic on one side of divider of a road and there will be no traffic on the other side. In this kind of situations it is possible to control the divider position automatically which reduces the traffic problems. Also using the movement of divider we can give traffic clearance for the ambulance when required. Measuring reasons of congestion is foremost thing in deciding the solution to it. The designing of the roads is done considering the adverse conditions and the clear distance amidst the vehicles vary depending on the actual conditions suggesting the difference between theoretical derivation and practical conditions. Regulations & legislations study help us in determining the actual onsite and the government determined flow of traffic. Traffic congestion can be determined with respect to travel time delay, speed change, volume occupied and level of service. Traffic congestion also depends on the pattern of city, weather it is centric, grid or organic pattern. Depending on different congestion scenarios every country has adopted its own measures like high density traffic toll way in US, vehicle exclusion zones in UK and flexible working



hours in UAE. Many other countries are in progress of adopting different measures for lowering down the effects of congestion. India with its growing economy is also experiencing growth in vehicular population although great variations in vehicle are seen but traffic free road is still in ideas.

II. LITERATURE SURVEY

[1] Movable Traffic Divider: A Congestion Release Strategy Author: AdvaitKawle, Dhruv Shah, KavinDoshi, Manish Bakhtiani, YashGajja, Pratibha Singh Publications: International Journal of Recent Advances in Engineering & Technology (IJRAET) 2017 Abstract: In recent years, with an ever increasing rate of development in metro cities around the world, there has been proportional increase in numbers of automobiles on the roads. Although the number of vehicles using the roads has increased, the static road infrastructure is almost the same and is unable to cope with changes like congestion, unpredictable travel-time delays and road-accidents that are taking a serious shape. Traffic congestion has been one of the major concerns faced by the metropolitan cities today in spite of measures being taken to mitigate and reduce it. It has emerged as one of the main challenge for developers in urban areas for planning of sustainable cities. In developing countries, like India, traffic is inherently chaotic and noisy. Identification of magnitude of traffic congestion is an essential requirement for defining the congestion and finding appropriate measures. The paper studies the existing traffic congestion on one of the major route of western express highway in Mumbai with the help of instruments like Metro Count, which counts the data for the no. of axles as well as the speed of the vehicles simultaneously recording the results obtained and carefully analyzing the data. The main focus of this study is aimed at understanding the recurring urban congestion, its measurement, precautionary measure and suggests a remedial measure for the same. The implication of widening existing roads or building new ones will only results in additional traffic that continues to rise until peak congestion returns to the previous level. The total available space within the city for the construction of roads, railways and other transportation is restricted. The paper discusses implementation of movable traffic dividers as congestion release strategy for metropolitan areas instead of traditional solution of widening the roads. The moveable traffic divider helps in there configuration of road capacity, so as to attain optimum benefit from roadway usage on the existing road.

[2] Implementation of Movable Road Divider using Internet of Things (IOT) Author: HemlataDalmia, Kareddydamini, AravindGoudNakka Publications: 2018 International Conference on Computing, Power and Communication Technologies (GUCON) Galgotias University, Greater Noida, UP, India. Sep 28-29, 2018 Abstract: The purpose of using road divider is to separating the two ways of traffic ie ongoing and incoming vehicles in the traffic. With growing population, the vehicles used per family increases, but there is limitation in resources and leads to more number of carson roads. In that case static road divider fixes the number of road lines on either side of road. This invites the better usage of available resources. In most of the cities, there are areas like industrial and shopping places where traffic flows only in one direction both in morning as well as in evening. In the peak hours, most of the time one road side is unutilized. It causes time loss of public and traffic jams. We aim to build a smart road divider in terms of automated road divider which moves or shift the lane directing the rush in traffic. Such type of mechanism of traffic system not only saves timebut also fuel. It can add one more lane based on the traffic in the particular direction. With the smarter planet application proposed below, manual dependency and manual traffic coordination is reduced. Like this a proposal of smart traffic isbuilt in which low, medium and high density of rush in the traffic will be shown in IOT server in using graph. It provides a better solution for traffic problem.

[3] Design and Implementation of Smart Movable Road Divider using IOT Author: B Durga Sri1, K Niroschal, Sheik Gouse1 Publications: Proceedings of the International Conference on Intelligent Sustainable Systems (ICISS 2017) IEEE Abstract: Road Divider is generically used for dividing the Road for ongoing and incoming traffic. This helps keeping the flow of traffic. Generally, there is equal number of lanes for both ongoing and incoming traffic. For example, in any city, there is industrial area or shopping area where the traffic generally flows in one direction in the morning or evening. The other side of Road divider is mostly either empty or under- utilized. This is true for peak morning and evening hours. These results in loss of time for the car owners, traffic jams as well as underutilization of available resources. Our idea is to formulate a mechanism of automated movable road divider that can shift lanes, so that we canhave more number of lanes in the direction of the rush. The cumulative impact of the time and fuel that can be saved byadding even one extra lane to the direction of the rush will be significant. With the smart application proposed below, we will also eliminate the dependency on manual intervention and manual traffic coordination so that we can have a smarter traffic all over the city. An Automated movable road divider can provide a solution to the above-mentioned problem effectively. This is possible through IOT. IOT refers to Internet of Things where the actual digitalization comesinto picture. Here sensors play a major role. We can achieve this using Arduino board. The sensors placed on the dividers sense the flow of traffic whether flow of traffic is smooth or not? If the flow is smooth on either side then there is nothingto worry but the lane which is having more traffic, the divider is moved to a certain distance to the smoother lane in order to smoothen the busy lane.

[4] Implementation of Movable Road Divider using Internet of Things (IOT) Author: HemlataDalmia;



KareddyDamini; AravindGoudNakka Publications: 2018 International Conference on Computing, Power and Communication Technologies (GUCON) Abstract: The purpose of using road divider is to separating the two ways of traffic ongoing and incoming vehicles in the traffic. With growing population, the vehicles used per family increases, but there is limitation in resources and leads to more number of cars on roads. In that case static road divider fixes the number of road lines on either side of road. This invites the better usage of available resources. In most of the cities, there are areas like industrial and shopping places where traffic flows only in one direction both in morning as well as in evening. In the peak hours, most of the time one road side is unutilized. It causes time loss of public and traffic jams. We aim to build a smart road divider in terms of automated road divider which moves or shift the lane directing the rush in traffic. Such type of mechanism of traffic system not only saves time but also fuel. It can add one more lane based on the traffic in the particular direction. With the smarter planet application proposed below, manual dependency and manual traffic coordination is reduced. Like this a proposal of smart traffic is built in which low, medium and high density of rush in the traffic will be shown in IOT server in using graph. It provides a better solution for traffic problem.

[5] Design and implementation of smart movable road divider using IOT Author: B DurgaSri; K Nirosha; Sheik Gouse Publications: 2017 International Conference on Intelligent Sustainable Systems (ICISS) Abstract: Road Divider is generically used for dividing the Road for ongoing and incoming traffic. This helps keeping the flow of traffic. Generally, there is equal number of lanes for both ongoing and incoming traffic. For example, in any city, there is industrial area or shopping area where the traffic generally flows in one direction in the morning or evening. The other side of Road divider is mostly either empty or under-utilized. This is true for peak morning and evening hours. These results in loss of time for the car owners, traffic jams as well as underutilization of available resources. Our idea is to formulate a mechanism of automated movable road divider that can shift lanes, so that we can have more number of lanes in the direction of the rush. The cumulative impact of the time and fuel that can be saved by adding even one extra lane to the direction of the rush will be significant. With the smart application proposed below, we will also eliminate the dependency on manual intervention and manual traffic coordination so that we can have a smarter traffic all over the city. An Automated movable road divider can provide a solution to the above-mentioned problem effectively. This is possible through IOT. IOT refers to Internet of Things where the actual digitalization comes into picture. Here sensors play a major role. We can achieve this using Arduino board. The sensors placed on the dividers sense the flow of traffic whether flow of traffic is smooth or not? If the flow is smooth on either side then there is nothing to worry but the lane which is having more traffic, the divider is moved to a certain distance to the smoother lane in order to smoothen the busy lane.

[6] Software Implementation of an Automatic Movable Road Barrier Author: RoopaRavish; Varun R. Gupta; K J Nagesh; AmruthKarnam; ShantaRangaswamy Publications: 2019 International Carnahan Conference on Security Technology (ICCST) Abstract: One of the most commonly used solutions to control the traffic in most of the cities is the road divider system. It divides the roads into equal parts/sides, one for incoming traffic and other for outgoing traffic. There may be many such lanes on each side of the road. The idea of equal road division for both sides in all time may cause inconvenience and the concept is practically inefficient. This is because the flow of traffic is not consistent throughout the day. During peak hours the flow of traffic is highly inclined in one direction. Hence, in order to improve and control real-time traffic, it is ideal to have a system of movable road divider. This paper discusses an approach towards implementing automatic road divider system and various customized solutions. Different ways to implement the aforementioned system for highly specialized environments are also discussed in this paper. This is shown through simulation. Our implementation uses methods to recognize the vehicle density on each side of the road and adjust the roadway barrier accordingly. This minimizes the traffic congestion and allows smooth flow of vehicles by providing ample commute area towards the side with a heavier flow of traffic.

[7] CONTROLLING OF TRAFFIC USING MOVABLE ROAD DIVIDERS Authors: S.Jyothirmayee, G.Vamshi Krishna, J.Nanditha, B.ShashankYadav The main aim of this project is reducing the traffic congestion in our daily life. Road Divider is generically used for dividing the Road for on-going and incoming traffic. This helps keeping the flow of traffic; generally there is equal width of lanes for both on-going and incoming traffic. The problem with Static Road Dividers is that the number of lanes on either side of the road is fixed. Since the resources are limited and population as well as number of cars per family is increasing, there is significant increase in number of cars on roads. This calls for better utilization of existing resources like number of lanes available. We are not using a machine and operating it manually rather operating it automatically by using two dividers namely normal and extended dividers. In this paper we place the ultrasonic sensor to one side of the road to detect whether there is any traffic congestion or not, if there is a congestion then the extended divider raises up and normal divider is set to ground level, else the normal divider is raised up and extended divider is set to ground level. And if there is a congestion then a message is sent to the nearby traffic control police stating that traffic congestion has occurred. So this is simple and can replace the heavy machines.

[8] IoT Deployed Automatic Movable Smart Road Divider to Avoid Traffic Problems Authors: Naveen N, Sowmya C N Road Divider is conventionally utilized for isolating the Road for ongoing and incoming traffic. This helps keeping the stream or flow of traffic. For the most part, there is equivalent number of paths for both ongoing and incoming traffic. For instance, in any city, there is industrial zone or shopping area where the traffic by and large streams in a single direction in the first part of the day or night. The opposite side of Road divider is for the most part either unfilled or under-used. This is true for peak morning and evening hours. This outcome in loss of time for the vehicle proprietors congested

driving conditions just as underutilization of accessible assets. Our thought is to figure a system of smart roaddivider that can move lanes or paths, with that goal we can have increasingly number of paths toward the hurry. The combined effect of the time and fuel that can be saved by adding even one additional path to the direction of the rush will be significant. With the brilliant smart application proposed, we will likewise dispose of the dependency on manualmediation and manual traffic coordination so we can have a more smarter traffic everywhere throughout the city. An Automated mobile street divider can give an answer for the previously mentioned issue successfully. This is conceivablethrough IOT.

[9] Public Cloud Integrated Road Lane Divider System NileshPatil, Parth Srivastava, Milan Ghori, Dharmik Dave and Darshan Jain Technology is one of the principle driving forces in the present world, it is transforming our lives and shaping our future. Various new technologies are making daily life more comfortable in their own ways, one such technology is Cloud Computing [1]. A cloud has many advantages like security, flexibility and cost effectiveness [1], due to which it can be used in many applications. One such application is in embedded systems. It helps us overcome many important demerits of standalone embedded system. In this paper we are presenting an application of public cloud integrated with embedded systems. Traditional road barriers are fixed to their position which makes handling of traffic difficult during peak hours. So to overcome this we came up with an idea of making movable barriers. This paper aimsto provide a more efficient way of solving problems occurring with the existing systems. By using cloud technology weare trying to help the commuters who face problems reaching their destination in an efficient way.

[10] Movable Road Divider RohitMohite, AbhijeetKaname, PankajKamble, PrashantKabutare, Prof. Rashmi wade In recent years, with an Ever Increasing rate of development in metro cities around the world, there has been proportional increase in numbers of automobiles on the roads. Although the number of vehicles using the roads has increased, the static road infrastructure is almost the same and is unable to cope with changes like congestion, unpredictable travel- time delays and road-accidents that are taking a serious shape. Traffic congestion has been one of the major concerns faced by the Pune city today in spite of measures being taken to mitigate and reduce it. It has emerged as one of the main challenge for developers in Pune for planning of sustainable cities. In Pune, traffic is inherently chaotic and noisy. Identification of magnitude of traffic congestion is an essential requirement for defining the congestion and finding appropriate measures. The main focus of this paper is aimed at understanding the recurring traffic congestion, its measurement, precautionary measure and suggests a remedial measure for the same. The implication of widening existing roads or building new ones will only results in additional traffic that continues to rise until peak congestion returns to the previous level. The total available space within the city for the construction of roads, and other transportation is restricted. This report will discuss the implementation of movable traffic dividers as congestion releasestrategy for Pune in the traffic prone areas instead of traditional solution of widening the roads. The moveable traffic divider helps in there configuration of road capacity, so as to attain optimum benefit from roadway usage on the existingroad.

III. SYSTEM DESIGN AND ARCHITECTURE

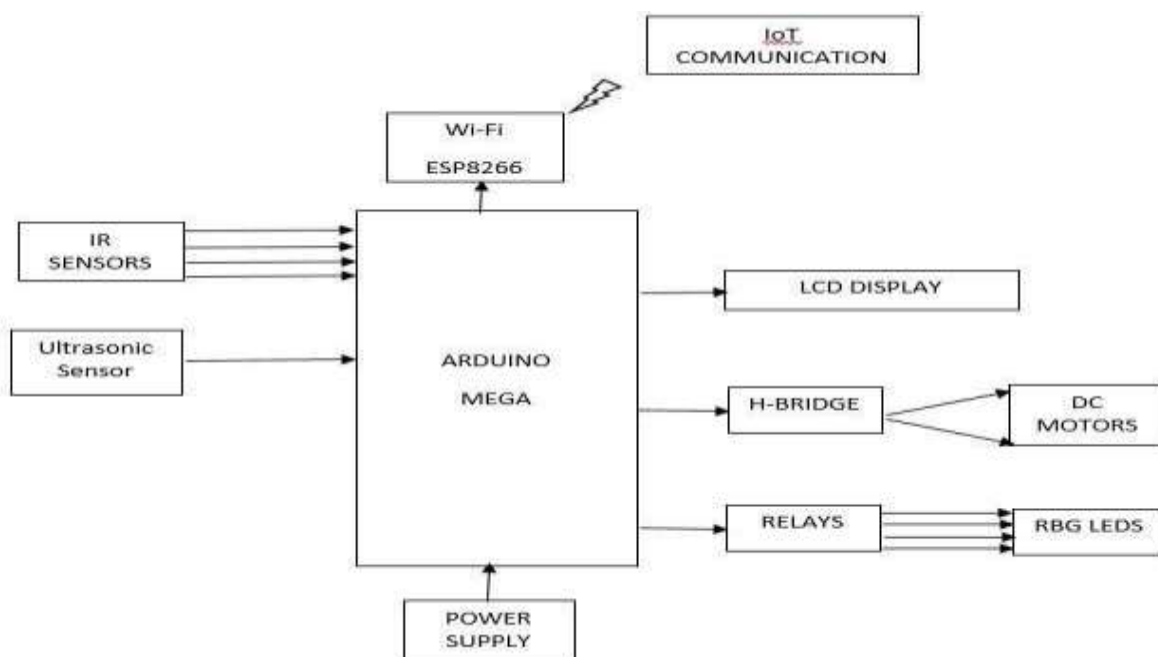

Fig 1. Block diagram

- In this proposed system, a module has been developed based on microcontroller that consists of an ultrasonic sensor which is used for measuring the traffic.



- Whenever ambulance is detecting on the either of the road side the color of the road will change and display on the LCDdisplay.

The main aim of this project is to automate change road divider & announce the status of the changes for users. In this system is also used to avoid accident problems. This project identifies the status of each car using IR transceivers and informs it to microcontroller. This project is used to avoid the car collision, thus we save the valuable human lives and losses. So this project is useful for road transport departments. The recent survey from the social analytics was said that the most disadvantages in Indian road traffic. Our proposed system mainly deals with the rectification of this disadvantage. Here we are introducing the new concept of artificial road divider. For the successful approach we are using sensors and for the execution we are using H-bridge and for the controlling operations we are using ATmega2560 microcontroller. When the car comes near the artificial position, the proximity sensor senses the car and gives its output to the microcontroller. The H-bridge is used for the forward and reverse movement of the divider.

IV. ADVANTAGES

- Using RFID a cloud is made to detect the arrival of ambulance and then make a way specially for it.
- These techniques help to decrease the traffic congestion and update information of traffic through cloud.
- Decrease time travel.
- Green Benefits include improved air quality, improved fuel efficiency, and reduced atmospheric CO₂.

V. CONCLUSIONS

The proposed structure helps to reduce the chances of traffic jams and to provide clearance of road for the emergency vehicles to an extent. In these proposed work we are aimed to clear the traffic in accordance to priority. It will help in to reduce the traffic highway. Also it is helpful for the government to apply traffic rules. And people will follow the rules of traffic. It's applicable in almost all areas in the Pune city. It will be applicable in the cross road and traffic zone.

REFERENCES

- [1] K.Vidhya, A.BazilaBanu, "Density Based Traffic Signal System", Volume 3, Special Issue 3, March 2014
- [2] PriyankaKhanke, Prof. P. S. Kulkarni, "A Technique on Road Tranc Analysis using Image Processing", Vol. 3 Issue2, February 2014.
- [3] RajeshwariSundar, SanthoshHebbar, and VaraprasadGolla, "Implementing intelligent Traffic Control System forCongestion Control, Ambulance Clearance, and Stolen Vehicle Detection" IEEE Sensors Journal, Vol. 15, No. 2, February 2015
- [4] Ms.PallaviChoudekar, Ms.SayantiBanerjee ,Prof.M.K.Muju, "Real Time Traffic Light Control Using ImageProcessing" Vol. 2, No. March.
- [5] ShabbirBhusari, "Traffic control system using Raspberry-pi", Global Journal of AdvancedEngineering TechnologiesISSN (Online), Volume 4, Issue 4- 2015, pp 413-415.MARCH 2015.
- [6] S.Lokesh, "An Adaptive Traffic Control System Using Raspberry PI", International journal of engineering sciences& research Technology, IEEE conference June 2014, pp 831-835.
- [7] SoufieneDjahel, "Reducing Emergency Services Response Time in Smart Cities: An Advanced Adaptive & FuzzyApproach", IEEE 2015, pp 978- 986
- [8] George Kiokes, "Development of an Integrated Wireless Communication System for Connecting Electric Vehicles tothe Power Grid", IEEE conf. 2015, pp 296-301.
- [9] Movable Traffic Divider: A Congestion Release Strategy (2017), vol-5,issue 1.
- [10] Chaudry, A. G. (2012). Evolution Of Transportation System In Dubai. National Industries Quarterly Vol-14.