

Implementation Of IOT Based Cloud Integrated Smart Classroom and Sustainable Campus

Sharath Kumar R¹, Yathish S Dhanajaya², Renukaprasad M R³, Subramani Gajanan Moger⁴

Student, Dept. of Electronics and Communication, KS Institute of Technology, Bangalore, Karnataka. ^{1,2,3,4}

Abstract: “In this era of smart classroom technology, students are more demanding innovative university campus life, and willing to use innovative learning methods. IoT and Cloud computing technologies can provide solutions for smart and a sustainable campus to improve learning methods of the students and improve the efficiency of everyday activities in the Institution. This project focus on the IoT paradigm in the teaching process with the integration of Cloud for education system. IOT in education provide student to learn new technologies that helps the students to create new ideas and logical for the social problems. IoT based cloud computing technology provide intelligence system, unified campus portal services, security and maintenance system. The digitally connected campuses enhances student learning and environmental sustainability. Students can use smart phones, PDA to access their homework assignments and test performance through online portals. Video can be uploaded in the cloud, online video Lecturing enables Students to attend classroom lectures remotely. IoT devices are used to track students who Skip their classes, send alerts help students to concentrate academic work regularly, and to find lost personal items. Through Digital devices payments can be made easy at cafeteria, office and in other admin activities. The hardware component of IoT consists of microcontroller board, sensor module, wireless and wired connections. Using the software module the information to and from sensor modules is processed and transmitted to cloud storage. This paper describes how efficiently IOT and Cloud Infrastructure restructure the traditional education and learning methods.

I. INTRODUCTION

Recently, Internet of Things and Cloud computing gains the attention of the universities to develop smart campus. Several peripherals, infrastructure and facilities are connected in a Smart Campus that provides smart lighting, security, tracking, efficient utilization of resources including manpower, electricity, water etc. Traditional classroom model requires equal time to be spent on both teaching and managing the workflow of the classroom. Mentoring and monitoring the academic related activities of the student becomes tedious. Faculty and the management of the institution faces hurdles to monitor the student academic closely. Thus, in order to achieve maximum utilization of the class hours, a new system is needed to take care of the workflow which highly reduces the time of faculty not to stick with managerial works and to increase the time of teaching and interaction with students. This project displays a technology that utilizes IoT along with cloud technology and application development platform to reduce the secondary work of mankind. This implementation let faculty to focus more on the primary work that is, teaching and to focus less on managing the workflow of the classroom.

IoT and Cloud based Smart Classroom

A literature review shows the various IoT and Cloud based Smart Classroom Systems. Internet of Things based Smart Classroom Environment system uses customized ARM Microcontroller. This system used for resource management, attendance monitoring, or faculty management. Using ID cards and wristbands, the location of the learner or guest was tracked. This smart classroom system also deals with intelligent parking system, dynamic ticketing system, etc. Another system uses touch-based interface and cloud-based framework storage system for a smart bench in a smart classroom was accessed through face recognition security system. These interfaces are provided in each bench in the class through which the Students will interact with notepad which helps them to take notes while listening to the class and it also help them for easy understanding and resource virtualization. This new technological advancement led to a change in education system. For Optimizing Classroom Usage, A Smart Campus was developed that describes the implementation of IoT and AI Technologies. The system includes sensing methods for measuring class possession for the lecture halls across campus. The system features are collecting live occupancy, collecting attendance patterns for 250 courses over two sessions, identification of conducted, cancellation of lecture hour and tests. It also uses Artificial intelligence techniques for attendance prediction. The system has a methodology for an optimal classroom allocation by predicting student's attendance.

Smart Campus Teaching Platform based on the 5G network implementation model is used to establish an online teaching platform. To obtain the student location information and monitor his presence in classroom, localization algorithm is utilized. The smart classroom was implemented using 5G network technology to improve the speed for student check-in time calculation and data transmission. Some technologies like face recognition, IoT, Artificial Intelligence and cloud

storage system can be effectively used to create Smart Classroom. Sensor to cloud data transmission may incur additional delay and security challenges. The system should offer an intelligent sustainable cloud computing. This project describes how efficiently IoT and Cloud Infrastructure restructure the traditional education and learning methods using the cloud storage for handling smart application through which interaction between teacher and student, between the various objects and IoT Sensors.

II.LITERATURE SURVEY

I.Smart Classroom Services System Design Based on Services Computing System

Author: Atika Rahmawati Yuliantoputri; Wardani Muhamad; Suhardi Suhardi

Published in: 2019 International Conference on ICT for Smart Society (ICISS)

Abstract: Smart Classroom is defined as a concept that supposed to accommodate synchronous and asynchronous learning using technology that integrates traditional and distance learning to cover its learning services by using artificial intelligence-based technology. The smart classroom also utilizes the connection of smart devices as a support so that teachers and students can approach various learning styles, participate interactively and share content. While the current smart classroom system mostly provide classroom environment, the proposed design of the smart classroom in this research will be consisted of designing a smart classroom system that covers distance learning activities under Smart Learning System (SLS) and in-class learning activities in Smart Teaching Environment (STE).SLS facilitates distance learning by enabling interactive teaching, customized learning, learning analysis, and ease of document access. STE is a class environment that utilizes a variety of smart devices to support in-class learning activities. By using Service Computing System Engineering Framework, SLS and STE will be integrated to fulfill the need for learning activities alignment in our education system by creating service innovation of smart attendance. While in-class students' attendance will be recorded by existing attendance recording methods, distance learning students' attendance will be recorded by applying smart attendance in SLS utilizing artificial intelligence to trigger randomized pop-up quizzes for attendance evidence. The result of the randomized quiz submissions will be validated for attendance student report based on defined parameters of class attendance. This proposed design of the smart classroom will be evaluated by calculating the cohesion and coupling degrees as evaluation principles for service-oriented software design. In conclusion, the proposed smart classroom has a main vision to ease the implementation of learning activities within in-class and distance learning...

II.Smart classroom: Design of a gateway for ubiquitous classroom

Author: Hichem Bargaoui; Rawia Bdiwi

Published in: 2014 International Conference on Web and Open Access to Learning (ICWOAL)

Abstract: In educational environment, the use of new pedagogies such as collaborative learning requires an evolution from a traditional classroom model to active classroom. The students should be able to share resources to collaborate with each other through computers, tablets, or other devices. The design of smart classroom should enable the control of audiovisual equipments, projectors, interactive whiteboards, in order to facilitate interaction among teachers and students. Ubiquitous computing or pervasive computing is a concept where processors and sensors are embedded in various physical objects to form a network and communicate information. Applying the pervasive computing can facilitate the collaborative learning by creating a smart learning environment. The ubiquitous classroom should be able to support interaction of heterogeneous devices connected through wireless links to a gateway. This paper presents a model of classroom that makes several smart devices such as laptops, tablets, projectors connected through a gateway in order to encourage communication of information between learners and the smart environment. Also, the gateway manages classroom smart devices by automatic detection and connectivity and it serves as application execution platform. Finally the gateway allows the classroom to be remote managed as well as the remote integration of application.

III.Smart Learning Environment: A Case on the Construction of Smart Classrooms in Colleges and Universities in Guangzhou

Author: Xinxin Deng; Rong Zhang

Published in: 2019 International Symposium on Educational Technology (ISET)

Abstract: Guangzhou is an important educational city in south China, but it has just started in the promotion of smart learning and the construction of wisdom classrooms. This paper analyzes the matching degree, satisfaction degree, advantages and disadvantages between the general multimedia classrooms and the smart learning classrooms. The construction situation, application degree and satisfaction degree of the smart learning classroom are comprehensively analyzed to find out whether Guangzhou colleges and universities are suitable for the upgrading and reconstruction of the smart learning classroom, and put forward constructive suggestions.

IV.A Smart Phone Integrated Smart Classroom

Author: Mahesh G.; Jayahari K.R.; Kamal Bijlani

Published in: 2016 10th International Conference on Next Generation Mobile Applications, Security and Technologies (NGMAST)

Abstract: Smart phones are playing a vital role in our day-today life, especially in the field of education. A student can use his personal smart phone for carrying his softcopies of his lecture notes (as storage device), for reading the lecture notes (display device), even it is a complete encyclopaedia due to the technological inventions in smart phone area. Even though smart phones have all these educational advantages, mobile phones are banned in many educational institutions as students misuse the phones during the class, by chatting with friends, playing games... This project involves research and survey to identify how usage of mobile phones at education institutions can be made under the control of authorities and how 1000s of lecture hours can be saved in a year using this device. We propose a mobile application which will help institution authorities to control the students' mobile phones and attendance will be taken by the students itself for saving the time of taking attendance. Students will be forced to run this application as their attendance will be marked through this application. This will also save the lecture time to some extent and will reduce the chances of students marking proxy attendances. Authorities can configure the list of white listed applications students can use in their phones when they are inside the campus.

V. Smart Timetable Plate for Classroom

Author: Yuan-Chih Yu; Shing-chern D. You; Dwen-Ren Tsai

Published in: 2010 10th IEEE International Conference on Advanced Learning Technologies

Abstract: Classroom usually has a timetable plate embedded on the wall near the front door. However, the only purpose for displaying classroom's timetable cannot fulfill the future digital classroom requirement. They need more automatic, integrated, and intelligent functionality in the classroom environment. Besides, the vision of future smart classroom is to select sustainable technology solutions that have the possibilities of dramatically improving the instructional delivery process and to engage the student in their learning experience. Therefore, the aspiration for providing more intelligent capability will go back to the improvement of classroom environment itself. Within the classroom, how to create a smart space is our goal. By means of introducing smart timetable plate, we can create a new use case for the application of smart classroom. The creative model not only bring the new style school living but also encourage the reform of traditional classroom environment

III. OBJECTIVES

- To build a prototype for smart classroom
- controlled by using Arduino uno, along with relays.
- The objective is to free teacher from secondary jobs.
- Application that would be pivotal for the entire functioning of classroom.
- Attendance process through facial recognition.
- Controlling the electrical devices.
- User Guidance app should give information about specific selection

IV. BLOCK DIAGRAM

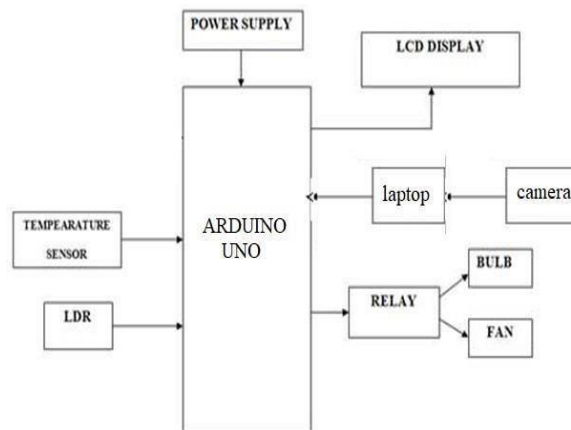

V. EXPERIMENT AND RESULT

- Automatic Attendance System using Face recognition.
- Environmental condition based Room Device control.
- User guidance App (Blynk) designed to provide information.

VI.CONCLUSIONS

The IoT based Cloud Integrated Smart Classroom for smart and a sustainable Campus will be an evolution in the educational environment resulting in high efficiency and effectiveness of classroom teaching methodology. This system will bring sincerity among student community to complete the work on time. Faculty and the management can spend more time on teaching and learning instead of spending time with managing and monitoring the workflow of the classroom. Thus, the proposed education system model provides intelligent, economic and environmentally sustainable campus

REFERENCES

- [1] Srinivas, Voore Subbarao and Pavithr.(2019) "A SURVEY ON INTERNET OF THINGS BASED SMART, DIGITAL GREEN AND INTELLIGENT CAMPUS." IEEE 2019 4th International Conference on Internet of Things: Smart Innovation and Usages: 1-6
- [2] Karan Phougat, Sachin Wakurdekar, Samarth Pruthi and Mohit Sinha. (2017) "An IOT approach for developing Smart Campus." International Journal of Innovative Research in computer and communication Engineering, 5(4) :7405-7412
- [3] Pagliaro F, Mattoni B, Gugliermi F, Bisegna F, Azzaro B, Tomei F and Catucci S. (2016). "A roadmap toward the development of Sapienza Smart Campus." In Proceedings of the International Conference on Environment and Electrical Engineering, Italy: 1–6.
- [4] Nie, X(2013). "Constructing Smart Campus Based on the Cloud Computing Platform and the Internet of Things." In Proceedings of the 2nd International Conference on Computer Science and Electronics Engineering (ICCSEE 2013), Hangzhou, China: 1576–1578
- [5] Asim Majeed and Mahmood Ali.(2018) "How Internet-of-Things (IoT) Making the University Campuses Smart?." IEEE 8th Annual Computing and Communication Workshop and Conference (CCWC): DOI: 10.1109/CCWC.2018.8301774
- [6] Sumeet Bajaj, Shreyas Kumbhakarn and Apeksha Bandekar.(2018) "SMARTBENCHES IN CLASSROOM." International Conference on Inventive Research in Computing Applications (ICIRCA 2018).
- [7] Thanchanok Sutjarittham, Hassan Habibi Gharakheili, Salil S. Kanhere and Vijay Sivaraman.(2019) "Experiences with IoT and AI in a Smart Campus for Optimizing Classroom Usage" of IEEE INTERNET OF THINGS JOURNAL 1 :1-13
- [8] Xin Xu, Dan Li, Mengyao Sun, Shichao Yan, Shujiang Yu, Gunasekaran Manogaran and George mastorakis. (2019) "Research on Key Technologies of Smart Campus Teaching Platform Based on 5G Network" Special Section on Roadmap To 5G: Rising To The Challenge, 7 : 20664 - 20675
- [9] Liu, M and Li L. (2018). "The construction of smart campus in universities and the practical innovation of student work." Proceedings of the International Conference on Information Management & Management Science, Chengdu, China :154–157.
- [10] Zhicheng D and Feng L. (2019). "Evaluation of the Smart Campus Information Portal" in Proceedings of the 2nd International Conference on Education and E-Learning, Bali, Indonesia: 73–79.