

# Static Analysis of Hybrid Composite Propeller Shaft

**Shivanand<sup>1</sup>, Shrivankumar B. Kerur<sup>2</sup>**

<sup>1,2</sup>Department of Mechanical Engineering, Basaveshwara Engineering College, Bagalkot-587101, Karnataka, India. (Visweshwaraya Technological University Belagavi, Karnataka, India).

**Abstract:** The purpose of this paper is to model, design and statically analyse the propeller shaft made from composite materials consisting of low carbon steel, epoxy, S-glass and T-700 fiber. The static structural analysis is administered for both conventional steel propeller shaft and hybrid composite propeller shaft to estimate the displacements, stresses, strains and forces in structures or components caused by loads that don't induce significant inertia and damping effects. Comparative results show that The steel shaft exhibits minimum value for directional deformation along y-axis, equivalent elastic strain, Maximum shear elastic strain and Maximum shear stress compared to hybrid composite shafts, which means that, steel shaft can withstand more load compare to hybrid composite one. But, for the Equivalent (Von Mises) stress hybrid composite shaft exhibits minimum value leading to more load withstand ability. From the analysis, it can be justified that for minimum load conditions, i.e., for light weight passenger's vehicle, the hybrid composite shafts can be considered rather than steel shaft thus reducing the overall weight of the vehicle and increasing the performance.

**Keywords:** Hybrid Composite Propeller Shaft, static analysis, ANSYS

## 1. INTRODUCTION

The propeller shaft is a unit of the automobile transmission system that connects the gear box output shaft to the input shaft of the differential at the rear axle. It transmits the power from the engine, clutch and gear box to the driving wheels of the vehicle through final drive and differential unit. It has to perform two functions. One is to transmit motion at an angle which is varying frequently and the other is to accommodate changes in length between the gear box and rear axle. Due to its longer length and high speeds, the propeller shaft has a tendency to vibrate at certain critical speeds. The critical speed varies directly as the shaft diameter and inversely as the square of its length. To keep theoretical speed frequency above the driving speed range, the propeller shafts need to be made with diameter as large as possible compared to its length. However, the increase in diameter increases its moment of inertia which would decrease its acceleration and deceleration.

Hybrid composites are more advanced composites as compared to standard fiber reinforced plastic (FRP) composites. They provide better flexibility as compared to other fiber reinforced composites. Normally it contains a high modulus fiber with low modulus fiber. The high-modulus fiber provides the stiffness and cargo bearing qualities, whereas the low modulus fiber makes the composite more damage tolerant and keeps the material cost at low. The mechanical properties of a hybrid composite are often varied by changing volume ratio and stacking sequence of various plies.

The purpose of this paper is to model, design and statically analyze the propeller shaft made from composite materials consisting of low carbon steel, epoxy, S-glass and T-700 fiber which can reduce the weight without affecting the performance of the shaft.

## 2. LITERATURE REVIEW

Dr.R.Ganapathi, Dr.B.Omprakash, J.Vinay Kumar [1] studied the modeling and analysis of composite drive shaft by replacing the conventional stainless steel with composite materials. They used composite materials in order to make a single long continuous shaft instead of conventional two piece steel drive shaft.

M. Pallavi et.al, [2] described the static and dynamic analysis of steel propeller shaft and composite propeller shaft made of glass fiber reinforced polymer. Primary objective was to match the torque bearing capacity, stiffness and weight savings of composite propeller shaft therewith of steel propeller shaft. The design constraints are angle of twist and natural frequency.

Atul Kumar Raikwar, Prof. Prabhash Jain & Rajkumari Raikwar [3] conducted a study on Design and optimization of automobile propeller shaft with composite materials using FEM Analysis. The weight was optimized up to the 82.04% as compared to conventional propeller shaft material.

Miss Priya Dongare, Dr. Suhas Deshmukh, [4] dealt with the static and modal analysis of composite drive shaft and development of regression equations. In this work an attempt was made to evaluate the suitability of composite material such as carbon/epoxy for drive shaft in automotive transmission.

Srikanth Reddy [5] dealt with design and analysis of a drive shaft. Presently used materials in the market for manufacturing are cast iron, cast steel. The purpose of this paper was to design the drive shaft made of Ni-Cr steel and compare it with steel material. The design was done in Solid works software and analyzed using ANSYS.

Sheik A. N. S [6] conducted study to replace a forged steel drive shaft by a composite drive shaft with enhanced mechanical property with less weight. In this paper aluminum was chosen as matrix metal of composite, and reinforcement materials are aluminum oxide ( $Al_2O_3$ ) and zirconium diboride ( $ZrB_4$ ) was fabricated.

G V Mahajan [7] in this paper design and vibration analysis of composites propeller shafts was undertaken. The aim was to replace a metallic drive shaft by a composite shaft. V. S. Bhajantri [8] also carried out a study in order to replace the steel shaft by composite shaft. In this work optimization of stacking sequence was done. Comparison was done for steel and composite shaft for max stress and deflection and concluded that the change in fiber orientation angle, varies the stress.

Bhirud Pankaj Prakash [9] studied that by using of composite material in shaft leads to significant saving in weight. In their work, weight reduction was carried out by using composite shaft to 2.7 kg from 10 kg of steel drive shaft. Sagar R Dharmadhikari [10] paper deals with the review of optimization of drive shaft using the genetic algorithm and ANSYS. Shivanand & Dr. Shrivankumar B. Kerur [11] conducted a study on exploration of hybrid materials for a propeller shaft in as aerospace applications. The results obtained from the Matlab are analyzed and the analysis determines that the hybrid material consisting of low carbon steel, epoxy, S glass and T 700 fibres is the best suitable for the propeller shaft to withstand maximum load with the least deflection. The orientation angle is considered to be 45 degrees.

Shivanand & Dr. Shrivankumar B. Kerur [12] undertook a comprehensive study on failure and Thermal Examination of hybrid materials for a propeller shaft in aerospace applications. This study presents the failure analysis of the hybrid material in ANSYS software. The main aim of this study was to check the suitability of the composite material comprising of carbon steel + epoxy + S glass + T 700 fibers for the propeller shaft applications.

### 3. MATERIALS AND MODELING

We know the importance of propeller shaft in automobiles. In the present work we are modeling two Propeller shafts one is steel and the other is composite one. Here we are going to discuss the Geometric considerations and design parameters for both the shafts and then the models are taken for meshing and analysis.

#### 3.1 Modeling of steel propeller shaft

**Table1:** Mechanical properties of Steel

Young's Modulus	210 Gpa
Shear Modulus	80 Gpa
Poisson's Ratio	0.3
Density	7860 kg/m <sup>3</sup>
Yield Strength	370 Mpa

Propeller shafts are designed on the basis of torsional loading. The commonly used materials for manufacturing the propeller shaft is low carbon steel with 10-18 % Chromium and 5-8 % Nickel. The yield strength of the material should be of 370N/mm<sup>2</sup> used for manufacturing propeller shaft is: The geometry for the steel propeller shaft is taken from the literature survey. The geometric dimensions, 3D Model and Mechanical properties for steel shaft are shown below.

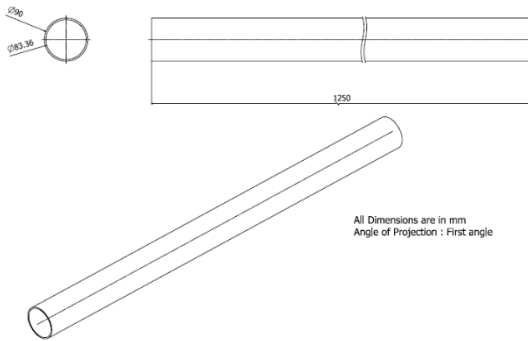

Fig 1: 3D Model of Steel Propeller Shaft

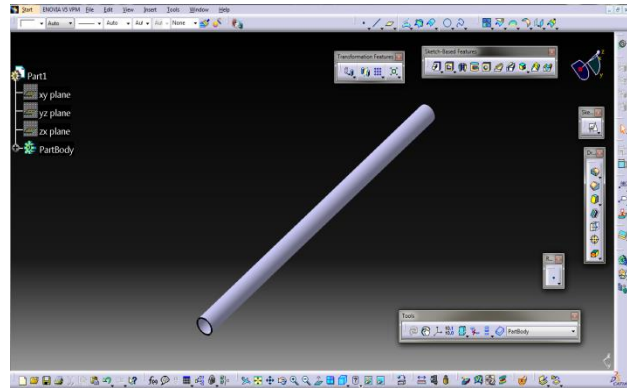

Fig 2: Geometric Dimension

Modeling of the steel propeller shaft is done using CATIA V5 R21. So the outer diameter of the Steel propeller shaft is 90mm, inner diameter is 83.36mm and length is 1250mm.

### 3.2 Modeling of composite propeller shaft.

The composite drive shaft should satisfy the design specifications such as static torque capability. The materials used for Hybrid Composite shaft in the present work are Low carbon Steel, S-Glass, Epoxy and T-700 fiber. The major role of Low carbon steel is to sustain the applied torque while the role of the carbon fiber epoxy composite is to increase bending strength. Modeling of the hybrid composite propeller shaft is done using ansys acp.

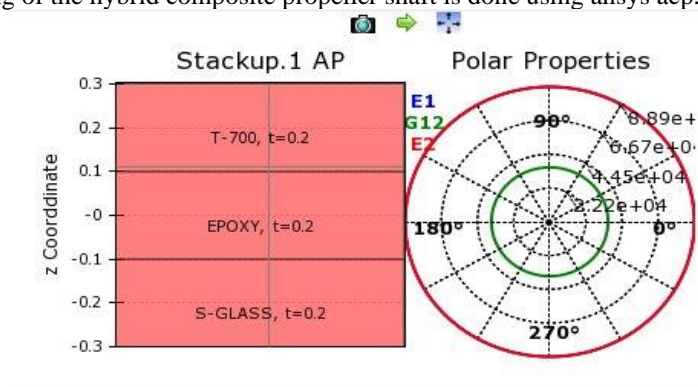

Fig 3: ACP post steps for adding layers

## 4. CODE VALIDATION

The problem is solved using Finite Element Analysis, the existing code is validated with the results of Mr. Swapnil Shinde[13], for accuracy and correctness. For the modeling of Steel Propeller Shaft, the inner and outer diameters are considered along with that the length of the shaft also considered, for analysis static and modal analysis have been carried out and for the same parameters validation is carried out. It is found that it agrees well with the results of published works. The result comparison for code validation is shown below.

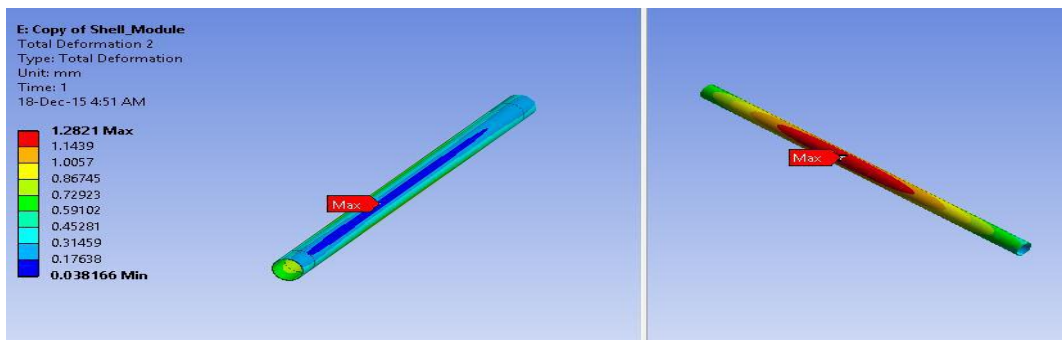

Fig. 4(a): Previous work model of Steel Propeller Shaft showing results for total deformation

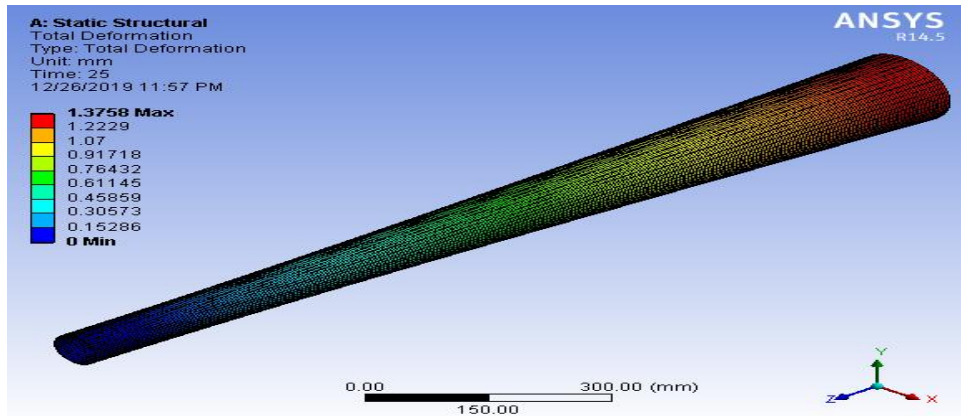

Fig. 4(b): Present work model of Steel Propeller Shaft showing results for total deformation

Table 2: Result Comparison of Steel shaft for total Deformation

Work Done	Maximum deformation in mm	Difference in values in %
Previous	1.2821	93.18 % accuracy
Present	1.3758	

The present work values and boundary conditions are given same as that of previous work. Load of 2500 N-m is applied and we have made 25 iterations for the present work to get higher accuracy. By comparing the results of previous and present work the maximum and minimum deformations are similar i.e. 93% accuracy. So we can go ahead with the further analysis.

### 5. RESULTS AND DISCUSSIONS

A static analysis is employed to work out the displacements, stresses, strains and forces in structures and components caused by loads that are not responsible to induce significant inertia and damping effects. A static analysis can however include steady inertia loads like gravity, spinning and time varying loads.

In static analysis, loading and response conditions are assumed, that is the loads and the structure responses are assumed to vary slowly with respect to time. The conditions of loading which will be applied in static analysis includes, externally applied forces, moments and pressures, Steady state inertial forces like gravity and spinning Imposed non-zero displacements. When the stress values obtained in this analysis crosses the allowable values then it will result in the failure of the structure in the static condition itself. This analysis is important to avoid such failures.

#### 5.1 Directional deformation along Y-axis for steel and composite shafts

The finite element analysis results of steel shaft is shown in the below Figure 5. The boundary conditions are taken in such a way that, one end of the shaft (left end side) is fixed, and at the other end (right end), Moment Load of 1500 N-m, 2500 N-m and 3500 N-m is applied.

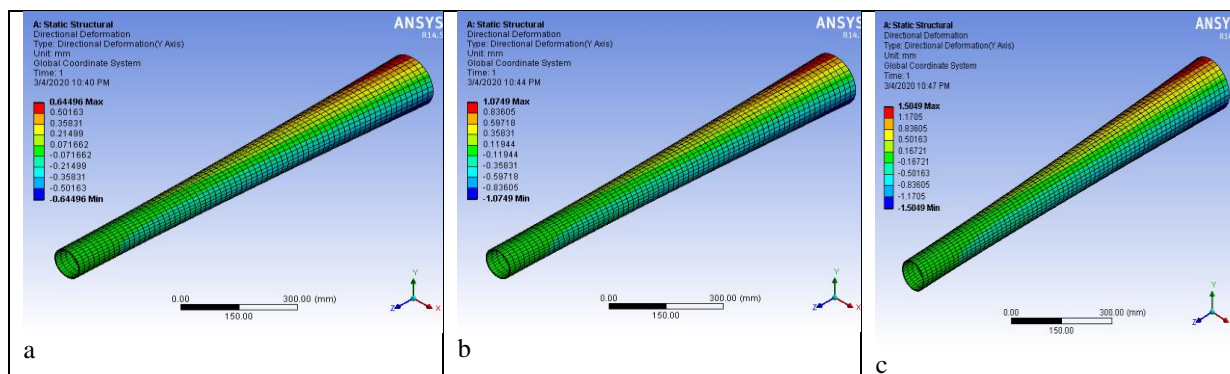

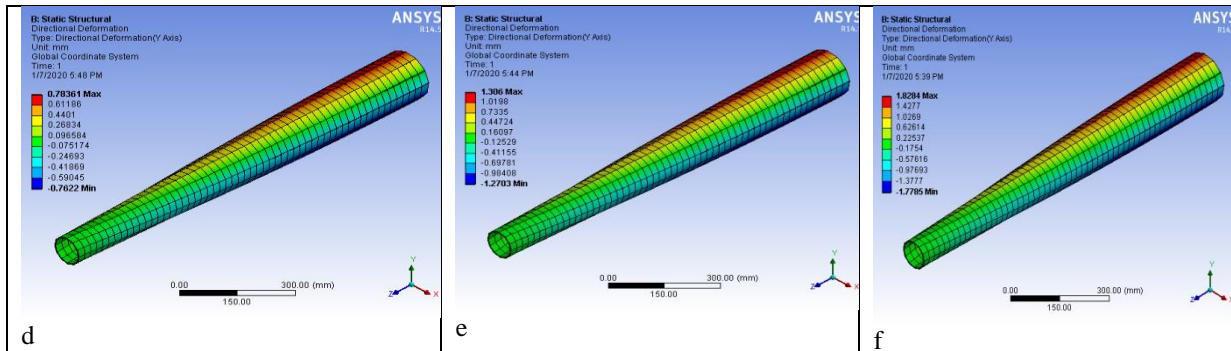

**Fig 5: a, b, c: Directional deformation along Y-axis for steel shaft and d,e,f: for composites at moment 1500 N-m, 2500 N-m and 3500 N-m respectively**

**Table 3: Result Comparison for Steel and Composite Shaft (Deformation along Y-axis)**

Deformation(in mm)/Moment	1500N-m	2500N-m	3500N-m
Steel Shaft	0.64496	1.0749	1.5049
Composite Shaft	0.78361	1.306	1.8284

From the table 3 we can say that steel shaft shows minimum deformation compare to composite shaft, i.e., steel shaft can withstand more load compare to Composite Shaft. But, for light weight vehicles we can consider the hybrid composite propeller shaft.

**5.2. Equivalent elastic strain for steel and composite propeller shafts**

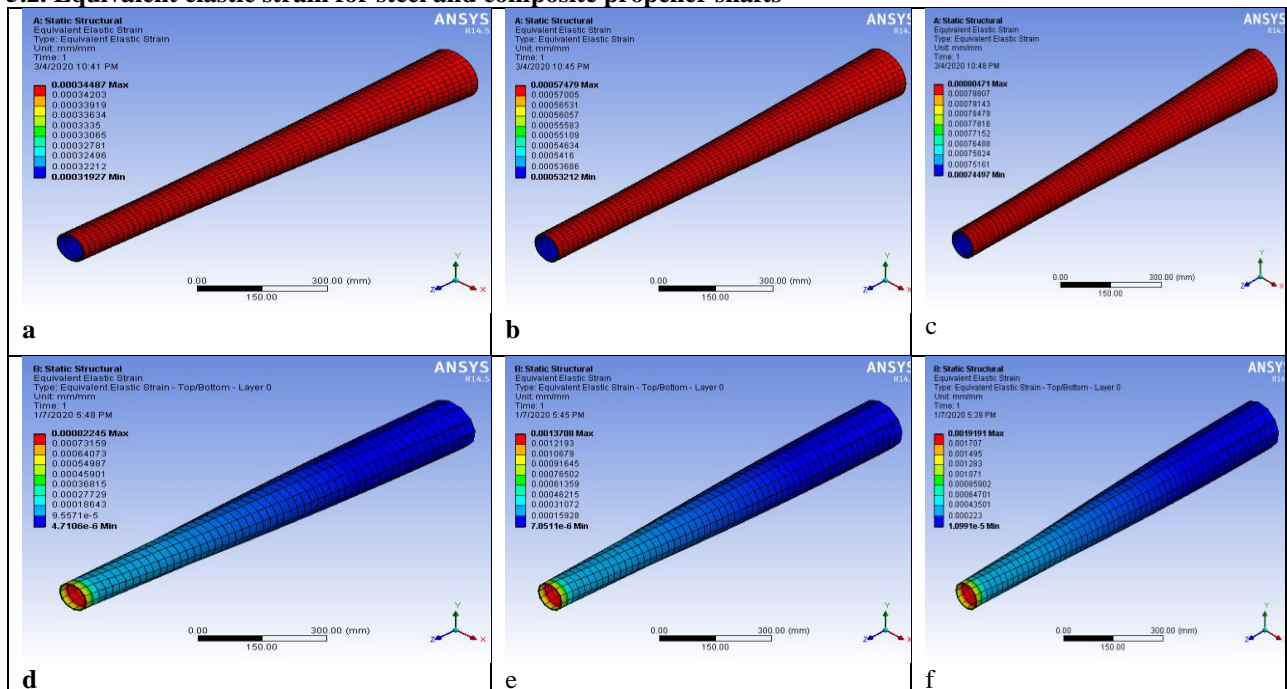

**Fig 6: a, b, c Equivalent elastic strain for steel shaft and d, e, f: for composites at moment 1500 N-m, 2500 N-m and 3500N-m respectively**

**Table 4: Result comparison for steel and composite shaft (Equivalent elastic Strain)**

Strain / Moment	1500 N-m	2500 N-m	3500 N-m
Steel shaft	0.0003	0.0006	0.0008
Composite shaft	0.0008	0.0014	0.0019



Figure 6 (a-f) Shows that equivalent elastic strain for steel and composite shaft for different moments such as 1500 N-m, 2500 N-m and 3500 N-m. From the table 4 we can say that steel shaft shows minimum equivalent elastic strain compare to composite shaft, i.e., Steel shaft can withstand more load as that of composite shaft. From the above scenario we can justify that for minimum load conditions i.e., for light weight passenger’s vehicle we can consider the composite shaft rather than steel shaft.

5.3 Equivalent (Von Mises) stress for steel and composite propeller shafts

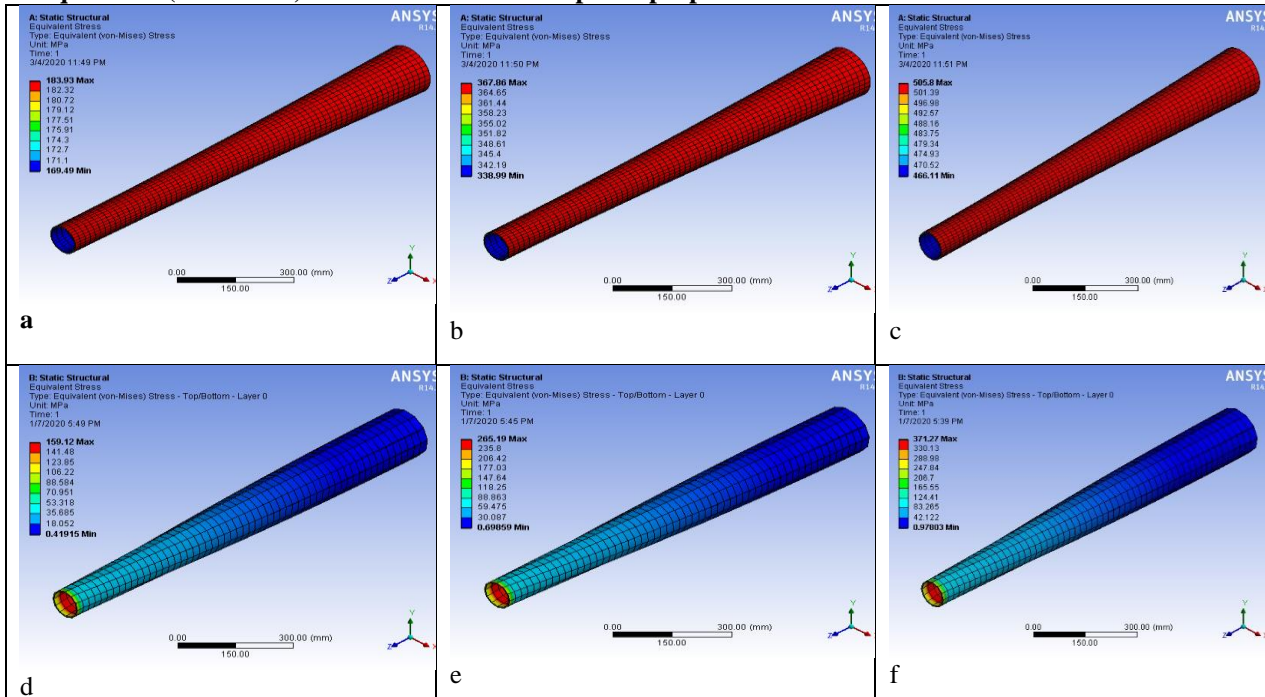

Fig 7: a, b, c: Equivalent stress for steel shaft and d, e, f: for composites at moment 1500 N-m, 2500 N-m and 3500N-m respectively

Table 5: Result comparison for steel and composite shaft(Equivalent Stress)

Stress (in Mpa)/Moment	1500N-m	2500N-m	3500N-m
Steel Shaft	183.93	367.86	505.8
Composite Shaft	159.12	265.19	371.27

Figure 7 (a-f) Shows equivalent (von-Mises) stress for steel and composite shaft for different moment loads such as 1500 N-m, 2500 N-m and 3500 N-m. From the table 5 we can say that composite shaft shows minimum equivalent stress compare to steel shaft, i.e. composite shaft can withstand more load as that of steel shaft because composite shaft contains more layers that help to withstand more loads. So, we can replace the Steel shaft by Composite Shaft.

5.4 Maximum shear elastic strain for steel and composite propeller shafts

Figure 8 (a-f) Shows maximum shear elastic strain for steel and composites shaft for different moment such as 1500 N-m, 2500 N-m and 3500 N-m. From table 6 we can say that composite shaft shows maximum value of maximum shear elastic strain compared to steel shaft. i.e., steel shaft can withstand more load than that of composite shaft. From the above scenario we can justify that for minimum load conditions i.e., for light weight passenger’s vehicles, we can consider the composite shaft rather than steel shaft.

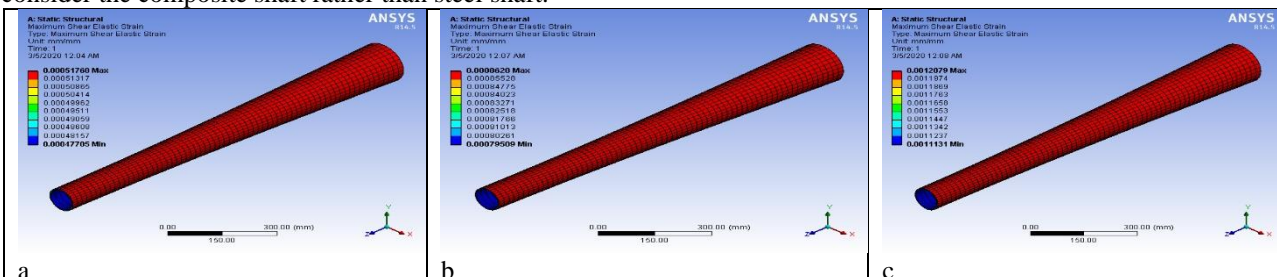

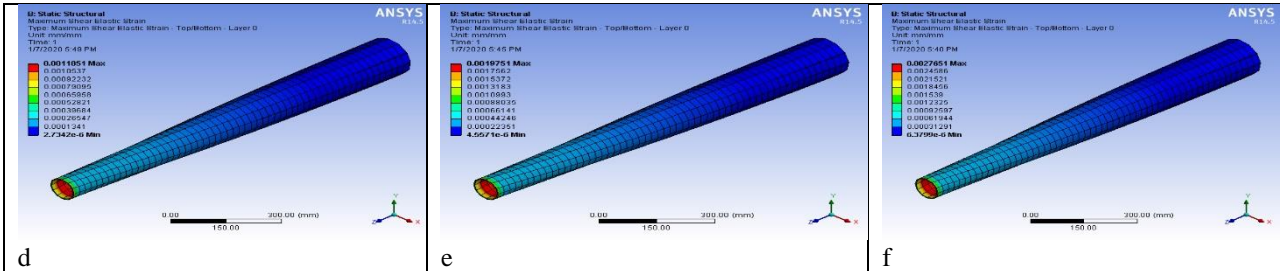

Fig 8: a, b, c: Maximum shear elastic strain for Steel Shaft and d, e, f: for composites at moment 1500 N-m, 2500 N-m and 3500N-m respectively

Table 6: Result comparison for steel and composite shaft (Max Shear Elastic Strain)

Strain/Moment	1500 N-m	2500 N-m	3500 N-m
Steel Shaft	0.00052	0.00087	0.0012
Composite Shaft	0.0012	0.0020	0.0028

5.5 Maximum shear stress for steel and composite propeller shafts

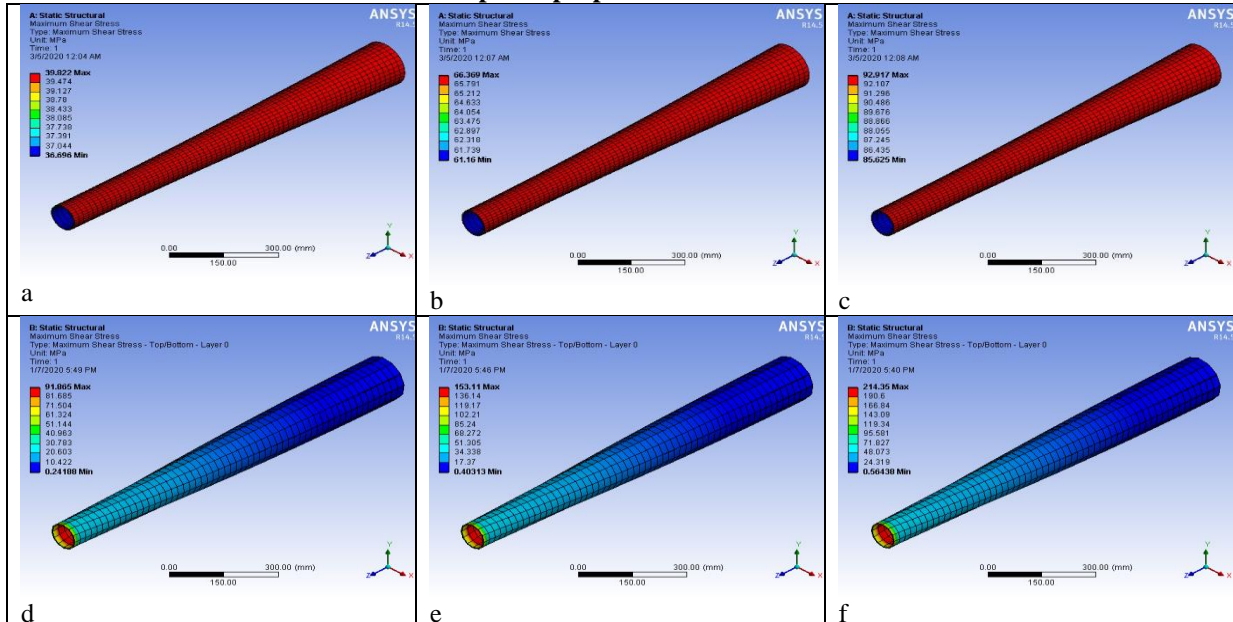

Fig 9: a, b, c: Maximum shear stress for Steel Shaft and d, e, f: for maximum composites at moment 1500 N-m, 2500 N-m and 3500N-m respectively

Table 7: Result comparison for steel and composite shaft (Max Shear Stress)

Max Stress (in Mpa)/Moment	1500 N-m	2500 N-m	3500 N-m
Steel Shaft	39.822	66.369	92.917
Composite Shaft	91.86	153.11	214.35

Figure 9 (a-f) Shows maximum shear stress for steel and composites shaft for different moment such as 1500 N-m, 2500 N-m and 3500 N-m. From table 7 we can say that composite shaft shows maximum value of maximum shear stress compare to steel shaft, i.e. steel shaft can withstand more load as that of composite shaft. From the above scenario we can justify that for minimum load conditions i.e., for light weight passenger’s vehicle we can consider the composite shaft rather than steel shaft.

**CONCLUSION**

FEA analysis has been performed to find the static behaviour of both the steel propeller shaft and Hybrid composite propeller shafts. From the above results and discussions, it can be concluded that the steel shaft exhibits minimum value for directional deformation along y-axis, equivalent elastic strain, Maximum shear elastic strain and Maximum shear stress compared to hybrid composite shafts, which means that, steel shaft can withstand more load compare to hybrid composite one. But, for the Equivalent (Von Mises) stress hybrid composite shaft exhibits minimum value leading to more load withstand ability.

From the above scenario it can be justified that for minimum load conditions, i.e., for the light weight passenger's vehicle, the composite shaft can be considered rather than steel shaft thus reducing overall weight of the vehicle and increasing the performance.

**REFERENCES**

1. Dr.R.Ganapathi, Dr.B.Omprakash, J.Vinay Kumar, "Modeling and Analysis of Composite Propeller Shaft", International Journal of Latest Engineering Research and Applications, 2017: 02(11):24-28.
2. M. Pallavi, T. Joel Swaroop Raj, A. Syam Prasad, M.Madhavi, "Experimental Investigations on Static and Dynamic Parameters of Steel and Composite Propeller Shafts for a Light Passenger Vehicle", IOSR Journal of Mechanical and Civil Engineering, 2015:12(4):01-07.
3. Atul Kumar Raikwar, Prof. Prabhush Jain & Rajkumari Raikwar, Design and optimization of automobile propeller shaft with composite materials using FEM Analysis", 2016:4(4):39 – 48.
4. Miss Priya Dongare, Dr. Suhas Deshmukh, "Static and Modal Analysis of Composite Drive Shaft and Development Of Regression Equations", International Journal of Engineering Research & Technology, 2012:1(10):1 - 6
5. Shrikant Reddy "Evaluation on the failure of an automobile drive shaft" International journal on latest trends in engineering technology, 2017:8(3):59-67.
6. Sheik A. N. S "Design to replace steel drive shaft in an automobile with hybrid aluminum metal matrix composites" International journal and magazine of Engineering and technology, 2017:4(6):294-301.
7. G V Mahajan "Composite Material: A Review over Current Development and Automotive Application" IJOSR, 2012: 2(11):01- 06.
8. V S Bhajantri "Design and analysis of composite drive shaft" IJRET, ISSN-2319-1163
9. Bhirud Pankaj Prakash "Analysis of drive shaft" international journal of mechanical and production engineering, 2013:2(2):1955- 1960.
10. S R Dharmadhikari "Design and analysis of composite drive shaft using ANSYS and GA" IJOR, 2013: 3(1):490-496.
11. Shivanand & Dr. Shrivankumar B. Kerur "Exploration of hybrid materials for a propeller shaft in aerospace applications", 'International Journal of Recent Technology and Engineering (IJRTE)' 2019: 8(2):4779-4788.
12. Shivanand & Dr. Shrivankumar B. Kerur, "Failure and Thermal Examination of hybrid materials for a propeller shaft in aerospace applications", 'International Journal of Recent Technology and Engineering (IJRTE)', 2019:8(2):6422-6428.
13. Swapnil Shinde, "Design and Optimization of Propeller Shaft Made Up of Composite Material", International Engineering Research Journal Page No 1046-1053.
14. Poonam Jagannath Shinde and Madhumita Chatterjee. "A Novel Approach for Classification and Detection of DOS Attacks." In International Conference on Smart City and Emerging Technology (ICSCET), pp. 1109-8537. IEEE, 2018.
15. Neha G. Relan and Prof. Dharmaraj R. Patil. "Implementation of Network Intrusion Detection System using Variant of Decision Tree Algorithm." In International Conference on Nascent Technologies in the Engineering Field (ICNTE), pp. 4799-7263. IEEE, 2015.