

POWER GENERATION USING SPEED BREAKER WITH THE HELP OF A RACK AND PINION MECHANISM

**Bheesetti Neeraj¹, Battula B N Sai Ram², Chatti V S Pavan Kumar³, Anaparthi Sai Kiran⁴,
B Pavani Sri Kavya⁵,**

UG student, Department of Mechanical Engineering, Vignan's Institute of Information Technology, Visakhapatnam,
India¹⁻⁵

Abstract- Energy is the most basic and essential need for all living things on the planet. Energy is the driving force behind any country's economic development. In today's world, conventional energy sources produce the majority of energy. However, the world's population is growing at an alarming rate, and conventional energy sources are becoming scarce. This paper harvests energy from a speed breaker by arranging gears and employing electronic devices. Saving a lot of money allows for the generation of a large amount of electricity. and, if implemented, will be extremely beneficial to the government. When a vehicle is in motion, it generates various forms of energy due to friction between the vehicle's wheel and the road, i.e., a rough surface. Heat energy is also produced when a fast-moving vehicle collides with the wind. Potential Energy to Electrical Energy Conversion is the principle at work. A power production system exists that converts the potential energy created by a vehicle moving up on a speed breaker into kinetic energy. The vehicle gains height as it moves over the inclined plates, increasing the potential energy wasted in a conventional rumble strip. When the breaker is tripped, they crank a lever attached to a ratchet-wheel mechanism, an angular motion converter, which rotates a geared shaft loaded with recoil springs. The shaft's output is connected to a dynamo, which converts kinetic energy into electricity.

Keywords: Rack, Pinion, Recoil Springs, Geared Shaft, Electronic Gadgets, Power Generation Using Speed Breaker, Dynamo.

I.INTRODUCTION

Many people in India are affected by a shortage of clean and reliable energy sources such as electricity. Around 1000 million people in India continue to rely on traditional biomass energy sources such as fuel, wood, agricultural waste, and livestock dung for cooking and other home requirements. Electricity is necessary at every point in our everyday lives, and population expansion has resulted in a reduction in conventional energy sources. Many more helpful power generation strategies have arisen as a result of the great growth of technology and familiarity with them. The newly developed techniques are concerned with cost-effectiveness. This research report outlines one such method of electricity generation.

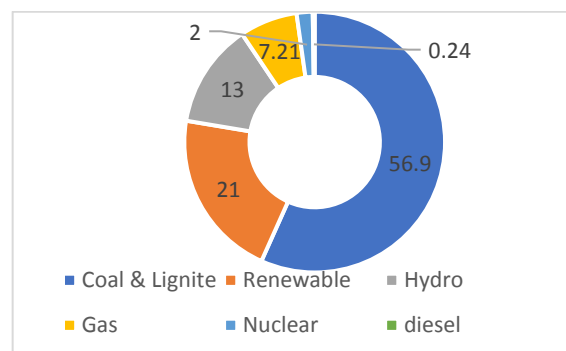

Fig1: Power Generation Capacity of India

Many automobiles drive on highways today, and their motion generates kinetic energy. These vehicles spend a lot of energy on the road because of speed breakers. The increased traffic and quantity of speed breakers these days underline

the need for the development of an inventive gadget that can harness the energy of vehicles that would otherwise be wasted on speed breakers to do some profitable activity. This kinetic energy can be captured at the speed breaker and used to create electricity. A fixed electro-mechanical unit is located beneath the speed breaker, as described in this project report. Roads are an important mode of transportation, and the number of wheels on the road grows in tandem with the population. Today, many autos travel on roadways, generating kinetic energy. Because of speed breakers, these vehicles expend a lot of energy on the road. Rising traffic and the increasing number of speed breakers these days highlight the necessity for the development of a creative device that can collect the energy of vehicles that would otherwise be squandered on speed breakers and use it to accomplish some profitable activity. This kinetic energy can be harnessed and used to generate power for the speed breaker. As explained in this project report, a fixed electro-mechanical unit is installed beneath the speed breaker. Roads are an essential mode of transportation. As the population grows, so does the number of wheels on the road. With the evolution of high-speed communications,

A rack and pinion linear actuator is composed of a circular gear (the pinion) that engages a linear gear (the rack), thereby translating rotational motion into linear motion. The rack is driven in a linear direction when the pinion is rotated. The pinion will rotate if the rack is driven linearly. Both straight and helical gears can be employed in a rack and pinion drive. There is no scientific evidence to support the assumption that helical gears function more silently.



Fig2: Rack and Pinion

While helical racks are less expensive, it has been demonstrated that they increase side torque on the data, boosting operating temperatures and causing premature wear. Straight racks require less driving force and provide more torque and speed per unit of gear ratio, allowing for lower operating temperatures and reduced friction and energy use. The maximum force that can be transmitted by a rack and pinion mechanism is determined by the tooth pitch, pinion size, and gear ratio. Arthur Ernest Bishop developed a low-cost press forging procedure for making the racks, which eliminated the need for gear teeth.

II.METHODOLOGY

The project is concerned with producing electricity from a setup similar to that used for speed breakers. Thus, the load applied to the speed breaker configuration is transmitted to the rack and pinion configurations. The rack and pinion arrangement is used here to convert the motion of the speed-receiving breaker into rotary motion.

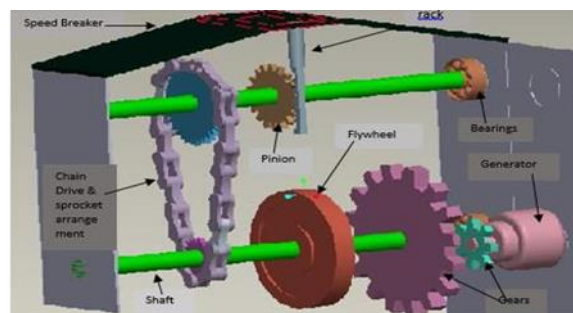

Fig 3: Schematic Diagram

The pinion's axis is linked to the sprocket arrangement. Two sprockets are used in the sprocket arrangement. One is in greater size, and the other is in a smaller size. A chain connects both sprockets and distributes power from the larger to the smaller sprocket. As power is passed from the bigger sprocket to the smaller sprocket, the speed available at the larger sprocket is approximately multiplied at the smaller sprocket. The smaller sprocket's axis is linked to a gear arrangement.

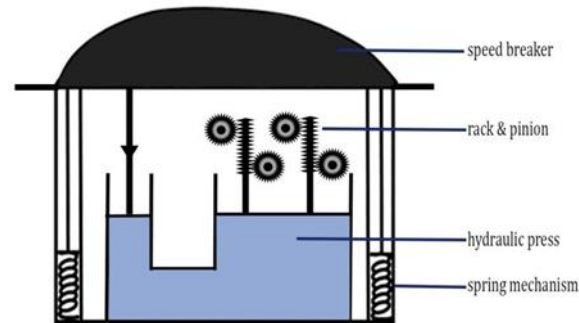

Fig 4: Speed Breaker Arrangement

We have two gears of varying sizes here. The larger gear wheel's axis is coupled to the smaller sprocket's axis. As a result, the multiplied speed located on the smaller sprocket wheel is transferred to the bigger gear wheel. The smaller gear is interconnected with the larger gear. The larger gear revolves at the multiplied speed of the smaller sprocket, while the smaller gear rotates at the multiplied speed of the larger gear in front of it increasing the speed even further. As a result, while the rotating motion's velocity the result obtained with the larger sprocket wheel is smaller., as power is transferred to the gears, the speed is eventually doubled to a greater speed. This speed is adequate to turn a generator's rotor, is fed into the generator. This emf is then supplied to an inverter and regulated. This controlled emf is now transferred to the storage battery and stored overnight. At night, this current is utilised to illuminate both sides of a long stretch of road.

III.DESIGN AND MODELLING

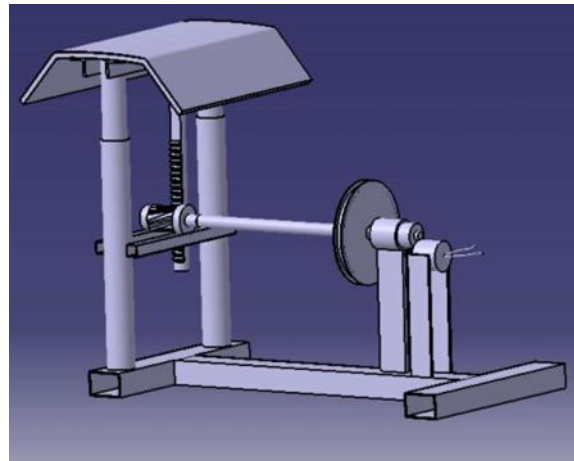

Fig 5: 3D Sketch of Assembly of Speed Breaker in CATIA Software

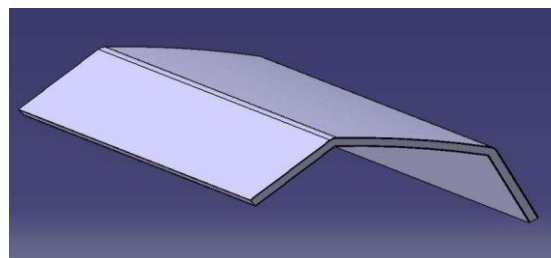

Fig 6: 3D sketch of the Speed Breaker plate

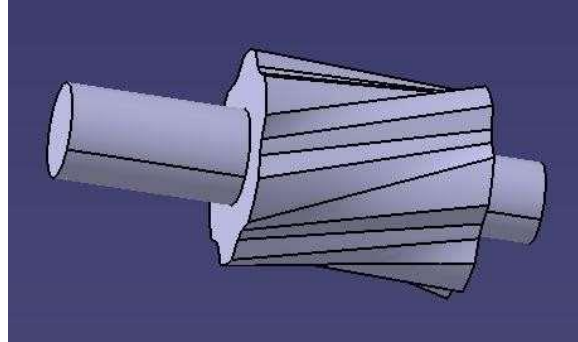

Fig 7: 3D sketch of Pinion in CATIA

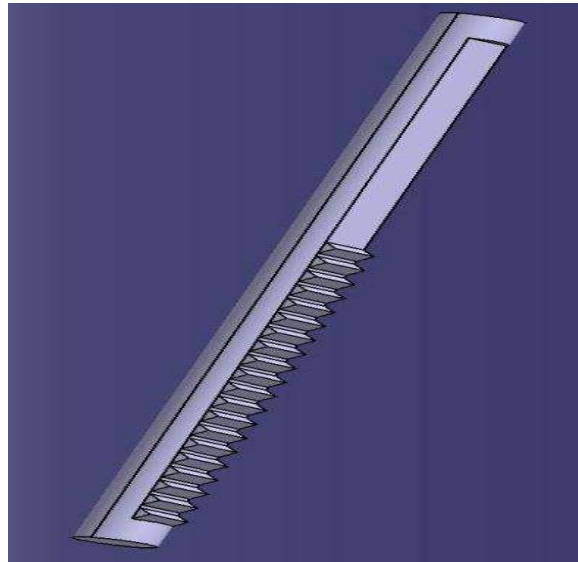

Fig 8: 3D sketch of Rack in CATIA

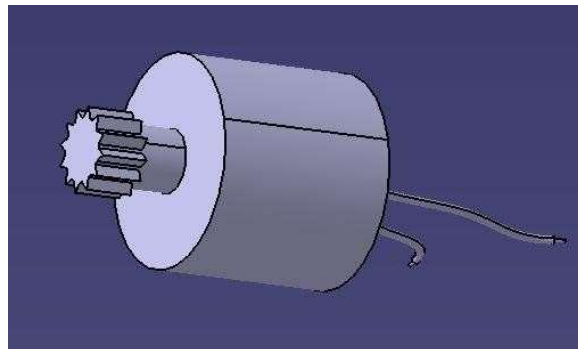

Fig 9: 3D sketch of Dynamo in CATIA

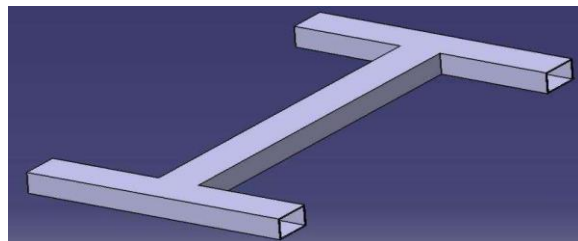

Fig 10: 3D sketch of Base in CATIA

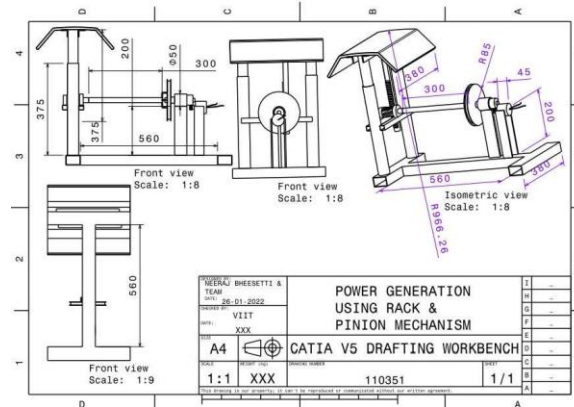

Fig 11: Drafting

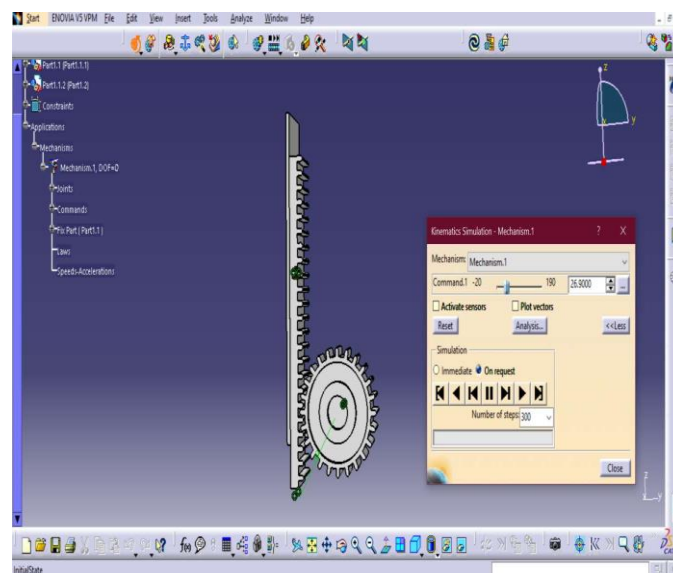

Fig 12: 3D Simulation of Rack and Pinion in CATIA Software

IV.FUTURE SCOPE

If implemented, it will greatly contribute to energy generation, lowering the burden on power plants and making more electrical equivalents available for industry, resulting in the nation's progressive development

V.RESULTS

Any vehicle going over the speed breaker has a mass of 300Kg (Approximately)

1. 15 cm is the height of the speed brake.
2. Work done = body weight multiplied by vehicle distance travelled
3. Here, Body Weight = 300 Kg x 9.81 = 2943 N
4. The distance travelled by the body matches the height of the speed breaker, which is 15cm.
5. Work done per second = $(2943 \times 0.15)/60 = 7.3575$ Watts
6. Power developed for a single-vehicle travelling at high speeds in a Breaker arrangement for one minute = 7.3575 watts
7. The power produced in 60 minutes (1 hour) = 441.45 watts

This mechanism of rotary motion is created by converting reciprocating motion into rotary motion. Rotational power (i.e., mechanical energy) is transformed into electrical energy by utilising a gear arrangement and a generator that generates electricity. And the electricity generated can be put to use in a variety of ways. When we consider a speed breaker height of 10 cm and a 1500 kg car crossing the speed breaker, we can generate a significant amount of power. For one minute, this equates to 24.52 W of power. Thus, an hour generates approximately 1.47 kW of power, which adds up to 35.31 kW of power per day. This equates to a large value and is sufficient to power 4-6 street lights per day.

**VI.CONCLUSIONS**

This sort of power generation has been identified as being less expensive than many other choices, and the model has less parts, thus assembly would be very cheap with all of the components readily available and no model-specific parts manufactured. This type of electricity generation aids in the conservation of conventional resources by generating electricity from readily available renewable natural resources. This method can generate electricity without relying on other factors and can meet the high demands of the future. It is also a non-harmful process for the environment. There is also no impediment to traffic flow. There is no need for manpower resources in this case because it is automatic. This has many applications, such as street lights and traffic lights, which prevent accidents from occurring "Electricity is a need in our daily existence." This power generation mechanism is yet another creative approach to creating green power to boost the country's development by better utilising available resources. Because of the population explosion, current power generation is no longer adequate to meet our needs. As the country's and the world's electricity demand rise in the coming days, it will be a great boon to the country and the world, as it will save a lot of electricity from powerplants that are currently being wasted in illuminating street lights. This research can be used to help our country develop by improving and more effectively utilising its resources. A country's development is directly proportional to how well and efficiently it uses its power supply. This is the time to put these creative ideas into action. This concept provides an alternative and contributes to the country's economy. Every country's development is the development of the world.

REFERENCES

1. Azam, A., Ahmed, A., Hayat, N., Ali, S., Khan, A.S., Murtaza, G. and Aslam, T., Design, fabrication, modelling, and analysis of a mechanical energy harvester (MEH) based on movable speed bumps for road use. *Energy*, 214, p.118894.
2. Mishra, A., Kale, P. and Kamble, A., 2013. Electricity generation from speed breakers. *The International Journal of Engineering and Science (IJES)*, 2(11), pp.25-27.
3. Ramadan, M., Khaled, M. and El Hage, H., 2015. Using speed bump for power generation-Experimental study. *Energy Procedia*, 75, pp.867-872.
4. Khodke, SS., More, V.M., Malkhede, Y.A. and Madke, A.V., Electricity generation with the use of a speed breaker mechanism.
5. Prasanth, M., Sankar, R., Dharshan, T., Nagaraja, R. and Dheenathayalan, P., 2002. The Crank Shaft is used to generate power from the Speed Breaker.
6. Rokonuzzaman, M. and Hossam-E-Haider, M., 2015. An examination of the speed breaker mechanism in order to improve the efficiency of power generation. At the International Mechanical, Industrial, and Materials Engineering Conference.
7. Islam, M.S., Rahman, S.K. and Jyoti, J.S., 2013. Generation of electricity using road transport pressure. (*IJESIT*), 2(3), pp.520-525.
8. <https://learnmech.com/wpcontent/uploads/2015/10/power2Bgereration2Busing2Bspeed2Bbreaker-e1555960862929.jpg>
9. https://www.researchgate.net/publication/313804513_Electrical_power_generation_through_speed_breaker