

IoT-Based Wireless Power Transfer for Charging Electric Vehicle

Rohini Thankam A¹, Sahana R², Saima Farheen³, Syeda Roshni Ahmed⁴

Student, Department of Information Science & Engineering, Atria Institute of Technology, Bengaluru, India^{1,2,3}

Assistant Professor, Department of Information Science & Engineering, Atria Institute of Technology,
Bengaluru, India⁴

Abstract: In the current scenario, we are facing issues due to the rising prices of fuel hence encouraging the use of electrical vehicles. A very small portion of the population is willing to buy an electric vehicle, among this population, few are hesitant due to the lack of charging infrastructure. Even though there are charging stations people need to spend most of their time waiting for charging their vehicles.

A wireless power transfer system offers an efficient and flexible means for charging electric vehicles. Hence, we have come up with the idea of implementing a wireless charging system for an electric vehicle. Wireless power transfer is achieved through inductive coupling between the transmitter and receiver coil. The transmitter coils are induced underneath the road and the receiver coils are installed in the electric vehicles. This project can open up new possibilities for wireless charging that can be used in our day-to-day life.

Keywords: Electric Vehicle, Wireless Power Transfer, Coils, Arduino UNO.

I. INTRODUCTION

Internet of Things (IoT) is a leading technology that integrates various devices and objects to make them smart and connected resulting in data exchange and enhancing the lifestyle of an individual. Things-enabled with IoT can help in commanding the various devices connected through voice or action. IoT helps people live and work smarter and also gain complete control over their lives. IoT enables companies to automate processes and also helps to reduce labor costs. It also improves service delivery and makes it less expensive. IoT is one of the most important technologies of everyday life, and it will continue to pick up steam as more businesses realize the potential of connected devices to keep them competitive. So, by using this technology systems are developed to transfer the power wirelessly.

II. RELATED SURVEY

Nowadays Electrical vehicle is a trending topic and it is also an important part of this smart world. The drawback of electric vehicles is typically limited. So, it requires frequent recharging. Not only for the electric vehicle but the Population is increasing exponentially and the problem due to this is, increasing traffic volume. All we know is that we have limited stock of the fuel on our earth so it needs time that we must switch to another way electricity is the best option for it and electric vehicle is an example of it. To charge electric vehicles, nowadays mostly used charging method is plug-in charging, this method consists of a plug that needs to be connected to the vehicle to start charging. In wireless charging, there is no need to ON-OFF the plug. Hence there will be less human interaction; it reduces the risk of electric shock due to wired connections [1].

We live in a world of technological advancement. New technologies emerge every day to make our life simpler. The conventional wire system creates a mess when it comes to charging several electric vehicles simultaneously. It also takes up a lot of electric sockets at the charging port. The objective of this paper is to implement an electric vehicle wireless charging station and charging platform to transmit electrical power wirelessly through space and charge the battery of an electric vehicle. The system will work by using inductive coupling to transmit power from a transmitter to a resistive load or battery of an electric vehicle [2].

With increasing the number of Electrical Vehicles (EVs) there is a need to construct new charging infrastructures. Compared with plugs and wires, wireless charging is more efficient. This paper studies the basic principle of resonant inductive power transfer which is commonly used in wireless charging. With an increasing number of these EVs, it is needed to solve a problem related to it.

Nowadays, the Electrical Vehicles industry is developing worldwide at full speed which brings various charging infrastructures to market. But still, wireless power transfer has some difficulties due to a lack of complete and exhaustive standards [3].

Electric vehicles, largely a curiosity in the past with limited options on the market, are becoming more popular and almost every major automaker will soon offer full battery electric vehicles (BEV) or plug-in hybrid electric vehicles (PHEV). Wireless charging using magnetic resonance provides a safe, efficient, and convenient alternative to having to plug in a cable to charge. Drivers can simply park in a wireless charging spot and walk away without having to remember to plug in or being forced to deal with dirty cables. This paper reviews the application of magnetic resonance-based wireless power transfer to the charging of electric vehicles. It includes an overview of the technology for this application, some performance data from a state-of-the-art system, a review of activities in standardization of the technology, and a discussion of some remaining challenges to widespread adoption [4].

The increasing requirement for convenience and safety has prompted an ever-growing demand for wireless charging, and with increasing efforts devoted to the development of electronic-based technologies, such as mobile phones and electric vehicles (EVs), we are now able to enjoy the benefit of wireless charging. Wireless charging technology for EVs could save the consumer from the laborious process of finding a charging point, connecting up the cable, and time spent waiting for the charge to complete, on the assumption that the cable is neither lost nor broken [5].

Road transportation is the majorly used transportation in the entire world. Usage of the car has drastically increased and the need for petrol and diesel has increased. So recently, Electric vehicles (EVs) are becoming popular, as they decrease reliance on fossil fuels and reduce greenhouse emissions. The problem of the Electric Vehicle is nothing else but the electricity storage technology, which is the major drawback today due to its unsatisfactory energy density, limited lifetime, and high cost. So, our project proposes a novel idea to charge the Electric vehicle wirelessly through the inductive power transfer principle using the transmitting and receiving coil while simultaneously decreasing the battery size and improving the convenience without the requirement of the cable [6].

Wireless power transmission (WPT) is the method that transfers electrical energy from the power source to electrical without any physical contact and it can be used to transfer power to electricity-dependent systems or devices. In WPT, electromagnetic energy is produced to transmit the energy from the power source (transmitter) to the load (receiver) via resonant inductive coupling. Output voltages and power have been investigated using suitable frequency and parameters. The model of Wireless Power Transmission (WPT) has been designed through Resonant Inductive Coupling. Other than that, the WPT system and also principle of magnetic wave between transmitter and receiver have developed with related parameters. Wireless power transfer has gotten more attention from researchers and inventors because this technology has the opportunity to change many things in the daily lifestyle as well as the industrial sector [7].

Electric vehicles (EVs) are a candidate to be the future of world transportation. The idea of changing fuel-charged transportation services to electrically charged systems is a breakthrough for efficient energy harnessing, conservation, and smooth energy transformation. Also, it is an effort to reduce detrimental emissions which have corresponding ramifications on a global scale. This directly impacts the present weather conditions plummeting the effects of global warming. In the current age of advanced technologies, many organizations host the manufacturing of these vehicles. However, charging is a well-known problem for EVs. Therefore, several methods have been proposed to charge EVs. One of the conventional ways is to charge a vehicle at a stop or a "station." The significant limitations are the time required for charging EVs and shorter traveling distances. Therefore, wireless charging has been proposed [8].

Wireless power transfer (WPT) using magnetic resonance is the technology that could set humans free from annoying wires. The WPT adopts the same basic theory which has already been developed for at least 30 years with the term inductive power transfer. WPT technology is developing rapidly in recent years. At kilowatts power level, the transfer distance increases from several millimeters to several hundred millimeter's with a grid to load efficiency above 90%. The advances make the WPT very attractive to the electric vehicle (EV) charging applications in both stationary and dynamic charging scenarios. This paper reviewed the technologies in the WPT area applicable to EV wireless charging. By introducing WPT in EVs, the obstacles of charging time, range, and cost can be easily mitigated. Battery technology is no longer relevant in the mass market penetration of EVs. It is hoped that researchers could be encouraged by the state-of-the-art achievements, and push forward the further development of WPT as well as the expansion of EV [9].

In this paper, a power transfer system to charge electric vehicles in motion using wireless power transfer is presented. The design consists of a circular receiver coil mounted on a vehicle and a larger circular transmitter coil fixed to the ground. Wireless power transfer is convenient, and safe, in electric vehicle charging has seen rapid growth in recent years.

Magnetic WPT systems rely on magnetic field coupling to transfer electric power between two or more magnetically coupled coils across the relatively large air gaps. In this paper, a wireless charging system for lightweight electric vehicles is designed, built, and tested. A. Wireless power transfer. Wireless power transfer (WPT), wireless energy transmission, or electromagnetic power transfer is the transmission of electrical energy from a power source to an electrical load, such as an electrical power grid or a consuming device, without the use of discrete human-made conductors. Wireless power is a generic term that refers to several different power transmission technologies that use time-varying electric, magnetic, or electromagnetic fields. In wireless power transfer, a wireless transmitter connected to a power source conveys the field energy across an intervening space to one or more receivers [10].

III. REQUIREMENT ANALYSIS

To implement the required project, we need to plan and list the specific components. They are as follows:

A. Arduino UNO



Fig. 1 Arduino UNO

Uno is a microcontroller board based on 8-bit ATmega328P microcontroller. Along with ATmega328P, it consists other components such as crystal oscillator, serial communication, voltage regulator, etc. to support the microcontroller. The Arduino Uno comes with USB interface, 6 analog input pins, 14 I/O digital ports that are used to connect with external electronic circuits. Out of 14 I/O ports, 6 pins can be used for PWM output. It allows the designers to control and sense the external electronic devices in the real world. It is an open-source platform, means the boards and software are readily available and anyone can modify and optimize the boards for better functionality. The software used for Arduino devices is called IDE (Integrated Development Environment) which is free to use and required some basic skills to learn it. It can be programmed using C and C++ language.

B. Rectifier



Fig. 2 Rectifier

A rectifier is an electronic device that converts an alternating current into a direct current by using one or more P-N junction diodes. A diode behaves as a one-way valve that allows current to flow in a single direction. This process is known as rectification.

C. Battery



Fig. 3 Battery



An electric battery is a source of electric power consisting of one or more electrochemical cells with external connections for powering electrical devices. When a battery is supplying power, its positive terminal is the cathode and its negative terminal is the anode.

D. LCD



Fig. 4 LCD

Liquid Crystal Display (LCD), electronic display device that operates by applying a varying electric voltage to a layer of liquid crystal, thereby inducing changes in its optical properties. LCDs are commonly used for portable electronic games, as viewfinders for digital cameras and camcorders, in video projection systems, for electronic billboards, as monitors for computers, and in flat-panel televisions. The optical properties of liquid crystals depend on the direction light travels through a layer of the material. An electric field (induced by a small electric voltage) can change the orientation of molecules in a layer of liquid crystal and thus affect its optical properties. Such a process is termed an electro-optical effect, and it forms the basis for LCDs.

E. Motor Driver

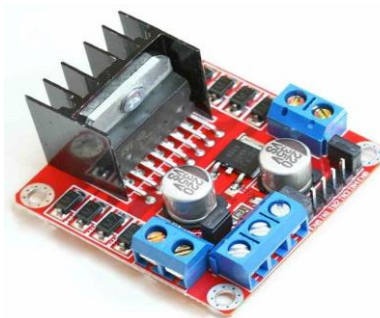

Fig. 5 Motor Driver

Motor drivers acts as an interface between the motors and the control circuits. Motor requires high amount of current whereas the controller circuit works on low current signals. So, the function of motor drivers is to take a low-current control signal and then turn it into a higher-current signal that can drive a motor.

F. NodeMCU



Fig. 6 NodeMCU

The NodeMCU ESP8266 development board comes with the ESP-12E module containing the ESP8266 32-bit LX106 RISC microprocessor. This microprocessor supports RTOS and operates at 80MHz to 160 MHz adjustable clock frequency. NodeMCU has 128 KB RAM and 4MB of Flash memory to store data and programs. Its high processing

power with in-built Wi-Fi / Bluetooth and Deep Sleep Operating features make it ideal for IoT projects. NodeMCU can be powered using a Micro USB jack and VIN pin (External Supply Pin). It supports UART, SPI, and I2C interface.

IV. METHODOLOGY

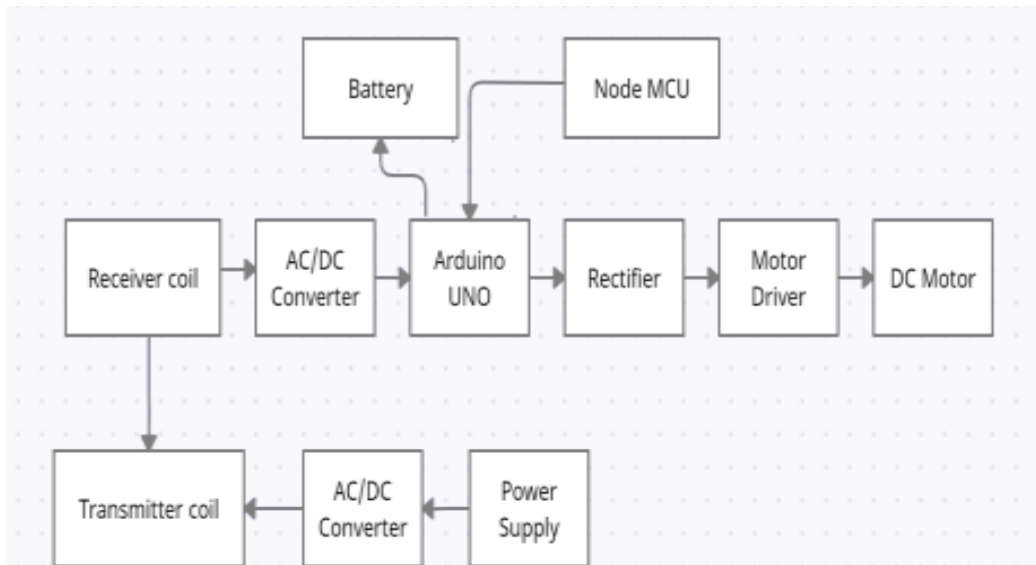

Fig. 7 Architecture Diagram

Wireless charging needs two kinds of coils that is transmitter coil and the receiver coil. The receiver coil receives the power from the transmitter coil through mutual induction. The transmitter coils are induced underneath the road and the receiver coils are installed in the electric vehicles. When both the coils come in contact parallelly with each other, the power is transferred from the transmitter to the receiver coil.

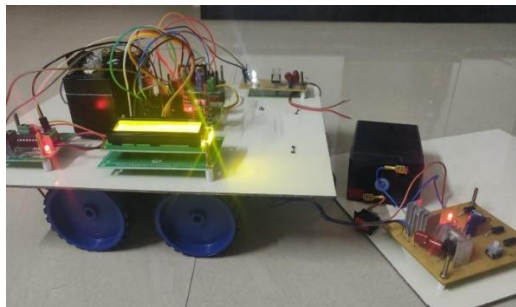

Fig. 8 Output

V. CONCLUSION

We hereby conclude after surveying the published papers that, this system helps in transferring power wirelessly to charge the electric vehicles using the transmitter coil that is located underneath the road and the receiver coil in the electric vehicle. This wireless power transfer technology effectively reduces the need for charging stations and also saves time. In the future, we plan to further explore wireless power transfer technology for large load applications. Our short survey study would help the new and interested researchers in the field of electric vehicle wireless charging to easily understand the current research works and the important parameters.

REFERENCES

- [1]. K.S. Phadtare, S.S. Wadkar, S.S. Thorat, A.S. Ghorpade. Title: "A Review on IoT based Electric Vehicle Charging and Parking System". International Journal of Engineering Research & Technology (IJERT). Vol. 9 Issue 08, August-2020.



- [2]. Shaikh Arbaz¹, Nayna Dahatonde², Nagori Meeran³, Shirgaonkar Zimad⁴, Shaikh Maseera. Title: “Electric Vehicle Charging System using Wireless Power Transmission, IoT and Sensors”. International Research Journal of Engineering and Technology (IRJET). Vol. 07 Issue: 05, May-2020.
- [3]. Chirag Panchal, et al, “Review of static and dynamic wireless electric vehicle charging system”, Engineering Science and Technology, an International Journal, pp.922-937, 21 June 2018.
- [4]. Morris Kesler. Title: “Wireless Charging of Electric Vehicles”. IEEE Transportation Electrification Community, 2018.
- [5]. Xiaolin Mou¹, Daniel T. Gladwin¹, Rui Zhao¹, Hongjian Sun. Title: “Survey on magnetic resonant coupling wireless power transfer technology for electric vehicle charging”, The Institution of Engineering and Technology, 2019.
- [6]. Dr. Kalaimurugan¹, D. Durga², D. Gokul Krishnan³, S. Prasanth⁴, E. Wilson Kumar. Title: “Design of Wireless Power Transmitting EV Charging Road”. International Journal of Advance Research, Ideas and Innovations in Technology, 2021.
- [7]. Puteri Athira, Tze-Zhang Ang, and Mohamed Salem. Title: “Resonant Inductive Coupling for Wireless Power Transmission”. International Journal of Energy and Power Systems (IJEPS), 2022.
- [8]. Govind Yatnalkar and Husnu Narman. Title: “Survey on Wireless Charging and Placement of Stations for Electric Vehicles”. IEEE, 2018.
- [9]. Siqi Li, Member, Chunting Chris Mi. Title: “Wireless Power Transfer for Electric Vehicle Applications”. IEEE Journal of Emerging and Selected Topics in Power Electronics, Vol. 3, No. 1, March 2015.
- [10]. Praveen Kumar, Viknesh, Martin Durai, Aravindhana. Title: “Electric Vehicle Charging in-Motion using Wireless Power Transfer”. SSRG International Journal of Electronic and Communication Engineering (SSRG-IJECE), Mar 2019.