

HYBRID SCOOTER

Mr. A.M. Shelake¹, Mr. D.M. Bhosale², Mr. S.A. Kale³

Lecturer, Department of Electrical, DKTE'S Yashwantrao Chavan Polytechnic, Ichalkaranji, India¹

Lecturer, Department of English, DKTE'S Yashwantrao Chavan Polytechnic, Ichalkaranji, India²

Lecturer, Department of Electrical, DKTE'S Yashwantrao Chavan Polytechnic, Ichalkaranji, India³

Abstract: Expeditious consumption of non-renewable fuel has enforced the essence of an substitute energy vehicle. Electric vehicles distribute as hopeful mechanism for the further generation transportation field. Due to few advantages of the electric vehicle can't coordinate with the traditional fuel powered vehicle which made the innovation of crossbred technology. Vigorous efforts are mainly towards administering a generality called as crossbred system by which one system will be charged while the other system provides dynamic power to the vehicle.

Keywords: Eco-Hybrid scooter, Petrol-electric system.

I. INTRODUCTION

Hybrid scooter is made up of 2 systems that is conventional (petrol based) and EV (by using battery). simply we can say that hybrid scooter is fusing of petrol plus electric battery. Today's world is dealing with the issue of air pollution and global warming reaches its censorious stage this hybrid scooter can reduces the drawbacks of both systems. by driving scooter on electric mode it is completely pollution free. This hybrid scooter have huge ability to produce less emissions and reduce the demand of fuel as it is current problem. Now a days so many vehicles types technologies are revealed with various types of vehicles although still today restricted solutions are to be supplied to people while the vehicles are totally run on the petrol system or totally run on the electric battery system. In this hybrid technology push button switch is provided to switch vehicle from electric to petrol and petrol to electric.

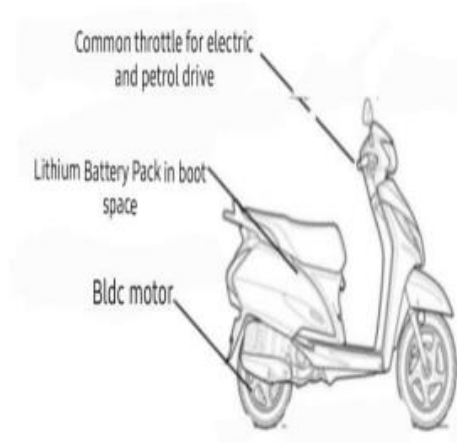

II. METHODOLOGY

List of steps that we carried out for this project work are as follows :

- 1) Fetch information from local market and social sites about hybrid technology.
- 2) Gathered details about hybrid scooter from various review papers.
- 3) Considered the advantages and disadvantages of traditional vehicle and electric vehicle.
- 4) After that we selected the project title and started working on it.
- 5) Gathered various equipment's and required material.
- 6) Assemble all the materials to the scooter .
- 7) Model of our scooter come into existence.

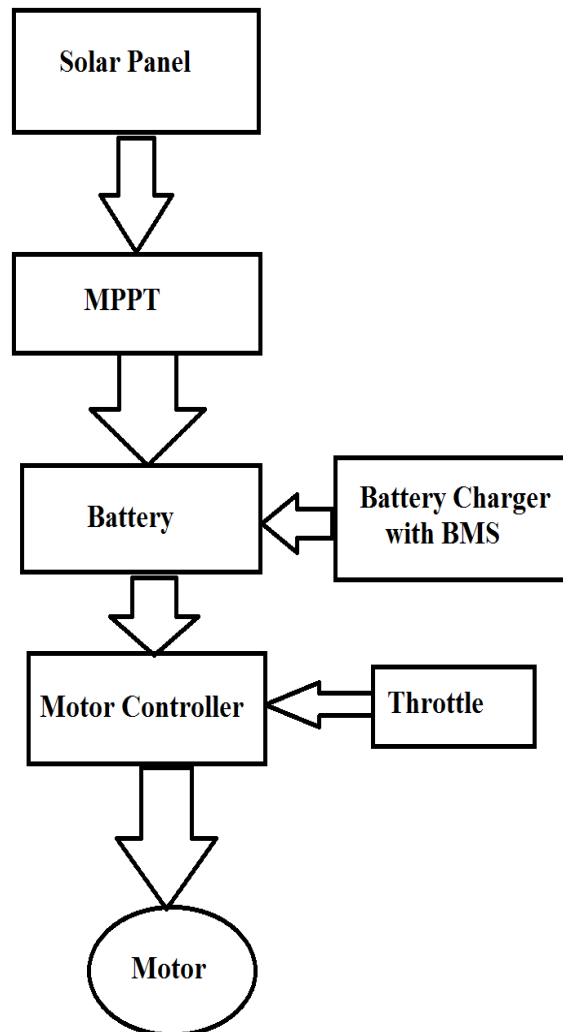

Block diagram of Electrical Circuit

The hybrid scooter is designed to save petrol. This scooter runs on electric charging as well as on petrol, in order to make a hybrid scooter the accelerator cable needs to be changed at the beginning where the throttle cable has to be used, this cable can be used on petrol as well as on electric. In the beginning why the 72 volt, 25 Amp battery used has to be connected to the plus (+) and minus (-) terminal of the controller and also the three wires of the used 1500 watt BLDC motor have to be connected to the middle three terminals of the controller. The lower terminal of the controller is connected to the throttle cable. Green and black 1.2v, red and black 5v are the second wire of the controller (red, yellow, black is connected to the 12v relay. The same black wire from the relay to the minus of the LED switch (-) and 4 terminal of relay has to be connected to plus (+) of LED switch. After this, after turning on the key switch of the car, the 12v supply will come to that wire, then the LED switch will have to be connected. The function of LED switch is to switch Operates in electric when ON and OFF.

ADVANTAGES:

- 1) Sustain 100 to 150 kg weight.
- 2) Gives good mileage.
- 3) Light weight .
- 4) Less noise.
- 5) Lower running cost .
- 6) Fuel economy increases.
- 7) Power and torque increases

**III. FUTURE SCOPE**

- 1) Independent Electric and Petrol Drive.
- 2) No changes required in vehicle for Installation.
- 3) Easy to Install .
- 4) 60 km of top speed in pure Electric Drive.
- 5) Compatible with 48v & 60v battery pack.
- 6) Easily Detachable Battery Pack.

IV. CONCLUSION

From this project we are able to reduce consumption of petrol and emissions from IC engine. It is ecofriendly and easy to cruise through traffic in city's based on the battery we can travel up to 40 to 55km. it is to switch between power sources. The hybrid scooter designed successfully which is environment friendly because we can travel half distance by electric system and half distance by petrol system. Fuel consumed by this vehicle is less as compare to other vehicles. This technology is very useful for us because by using this type of vehicle we can save money required for fuel.

REFERENCES

- [1] (IJAEM) Volume 2, Issue 1, pp: 01-05 www.ijaem.net ISSN: 2395-5252
- [2] The Electric Vehicle Conversion Handbook | Author: Mark J. Warner. Electric & Hybrid Vehicles | Author: A.K. Babu.
- [3] Fundamentals and Applications of Lithium-ion Batteries in Electric Drive Vehicles.
- [4] <https://electricvehiclenewsindia.com/electricpetrol-hybrid-scooter-india-2022/>
- [5] <https://www-bikedekhocom.cdn.ampproject.org/v/s/www.bikedekho.com/honda/activa3g>