



Web Based Career Guidance System

Nikhil Lohar¹, Yash Sanadhya², Riddham Paliwal³, Milind Singh⁴, Payal Sachdev⁵

Student, Computer Science Engineering, Geetanjali Institute of Technical Studies, Udaipur, India^{1,2,3,4}

Asst. professor, CSE Department, Geetanjali Institute of Technical Studies, Udaipur, India⁵

Abstract - In today's world selection of the right career is very important. It is a very complicated and difficult task for the students. While choosing the right career one should think with respect to their skills, area of interest, abilities and capabilities. This is not as simple a task as it sounds, as most of the students get confused. Our application is a solution for all these problems. It is an approach to provide proper guidance to the students by recommending them careers after 10th and 12th grade. The students are evaluated on the basis of the aptitude test and a proper career guidance is given to them to achieve the heights of success in their life. In this system we have used different data mining algorithms for better visualization.

Key Words: Data Mining, Career, K-means, Web Development

1. INTRODUCTION

Choosing a career has always been challenging for everyone since very long. Web Based Career Guidance System has been developed for the students who have completed their 10th grade and 12th grade. This system is developed to clear all the confusion in the minds of the students. Our website is a true relief for students and their parents. The students will first need to register with our website and then login with the same credentials and then select the grade after which they are looking for career guidance (i.e after 10th or after 12th). After selecting the grade the students can proceed with the aptitude test. The aptitude test consists of different sections like quantitative, logical and verbal. After successful completion of the test the students will receive a report which has a detailed analysis of the test and the appropriate career recommendation. The students can then explore more about the particular career option from our website. The students can also view all the colleges for that particular field along with the city in which they are located, fees and ratings on our website. We have used Data Mining Algorithm, k-means which gives us a pictorial representation for better visual analysis. The output of the same is stored in the Backend and again displayed to the user in Frontend. A contact form has also been included in our system. In case of any difficulty or query the students can contact us and get their doubts solved. They can contact us on the email id provided in the website. This application will contribute a lot if used effectively

2. EXISTING SYSTEM

The existing system involves one to one counselling, or pen and paper guidance. This has many drawbacks such as less accuracy, unavailability of the counsellor and many more. There are also some websites available which guides the students based only on their academic marks without considering their aptitude. The GUI of some websites is not user-friendly, which makes it difficult for the students. There is no such website which takes the input from the students and provides them with a detailed report and an appropriate career along with the explanation of why to move ahead with the recommended career and a list of colleges.

3. AIM & OBJECTIVE

In the modern age, choosing the right career option is a very tough assignment for students. In the last decade, the number of career options increased tremendously. Most of the students are even unaware of these career options. Many career counsellor platforms charge high fees which are not affordable for everyone. So there is a need for a career counselling website which is free and user friendly. The main objective of our system is to provide right guidance to the students by recommending the appropriate career. Along with this our system also gives brief insights to the students about the recommended career option. The students also get a complete list of colleges which will reduce their time and efforts.

4. WEB BASED CAREER GUIDANCE SYSTEM

The existing system has many drawbacks. In the proposed system we have used advanced technologies such as Data mining algorithms and Web development. This application has been developed using various languages such as HTML5, CSS, Javascript, PHP. For database storage we are using XAMPP Server i.e MYSQL and APACHE. This application has different modules like Login, Registration, Aptitude test, Result, Report Generation and List of Colleges. In our system we have used data mining techniques such as clustering, classification and data mining algorithms such as k-means for graphical visualization. This system does not require the involvement of manpower



5. WORKING OF WEB BASED CAREER GUIDANCE SYSTEM

The Web Based Career Guidance System is easier to access anywhere and anytime. This system provides the students a right career path by suggesting appropriate careers.

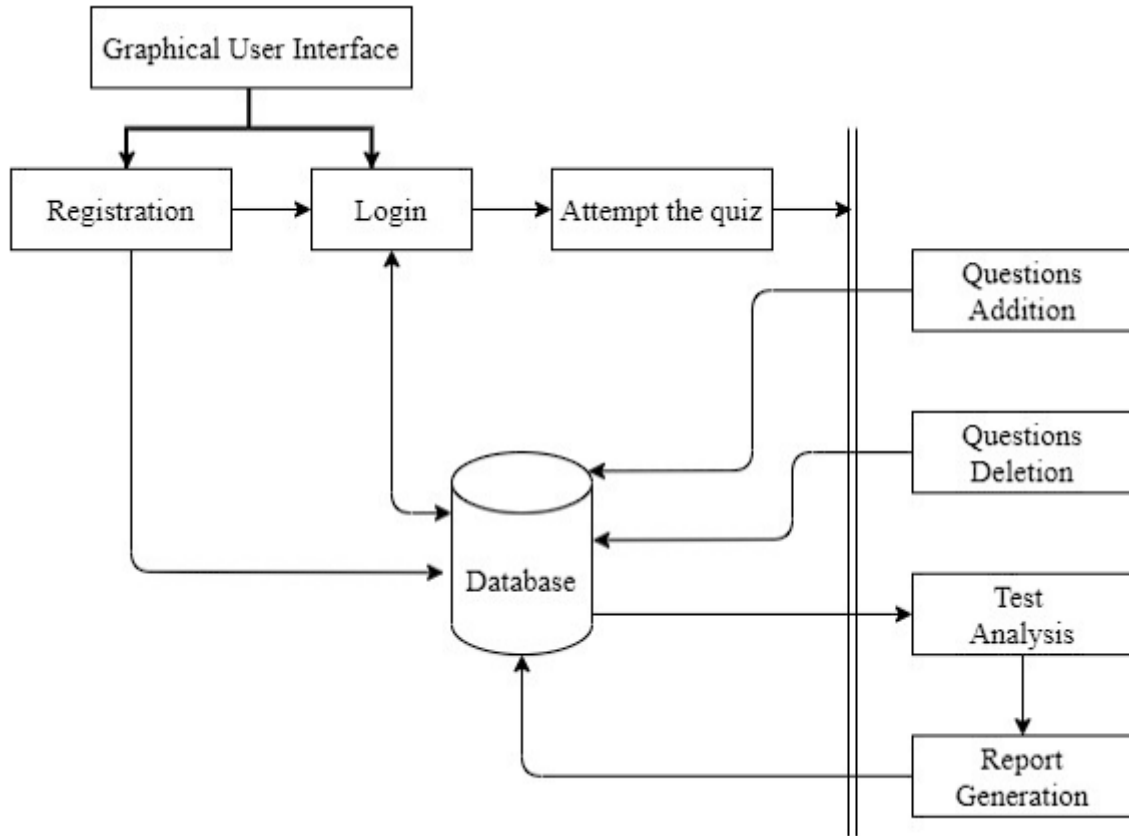

System Architecture The project methodology involves taking input from the students and displaying the output after performing the analysis. For students' input we have focused on Personal details, Academic details and Aptitude tests. When the students visit the Career Guidance Website they will be first prompted with a welcome screen and landing page where the students get brief ideas about the website. If the student is visiting the website for the first time he/she would need to register to enjoy all the services offered. After registering the student will be provided with username and password. The same credentials should be used by the students to log in to the website. The student then needs to select an appropriate grade (10th grade or 12th grade) after which he/she is looking for career guidance. When the student selects the standard he/she is required to enter the Academic details. Where the student needs to enter all the academic details including curricular as well as extracurricular activities. The students area of interest plays a vital role in the selection or guidance of career path. Here the student is supposed to enter his or her area of interest which can be arts, science or commerce after 10th grade or Engineering, Doctor, Architecture, Fashion Designing etc after 12th grade. The student is now prompted with a quiz window. The difficulty level of both the quizzes is different. At the end of the quiz, the student will be provided with a report along with career recommendations. The student can also browse through all the colleges of the recommended stream.

6. USE CASE DIAGRAM

The use case diagram for Web based Career Guidance System is as shown below.

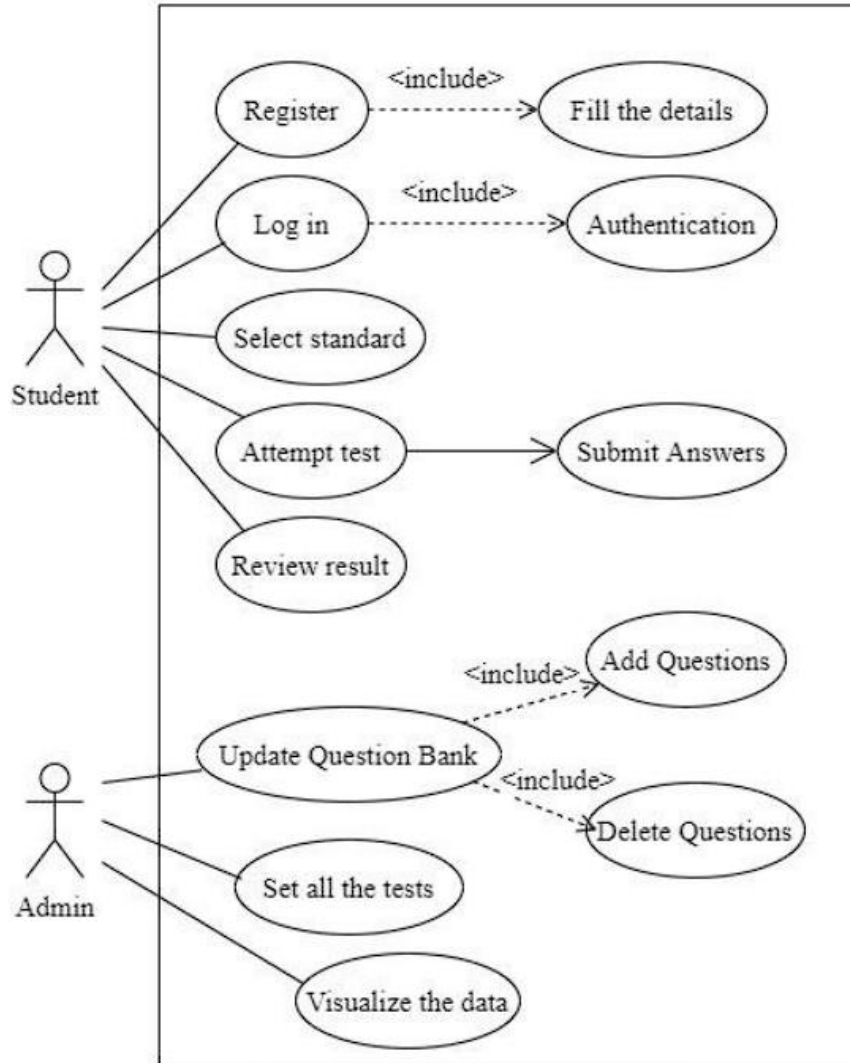

[1]

- Register : Fill in the required details and register to the system
- Login : On logging on, the user is prompted for the username and password. The user enters the username & password to enjoy the services of the career guidance system.
- Select standard : The student needs to select an appropriate grade(10th grade or 12th grade) for which he/she is looking for career guidance.
- Enter academic marks : Here user needs to enter all the academics related details including curriculum as well as extracurricular activities.
- Select Favorite Subject from Academics : The user needs to select his or her favorite subject from the academics.
- Attempt tests : The user needs to attempt all the tests to get a proper career path.
- Review result : Both the student as well as the admin can review the final result.
- Update the Question bank : The admin can update the question bank by adding or deleting questions.
- Set all the tests : The admin has to prepare a questionnaire for all the tests.
- Visualize the data : The admin can then visualize the data for better understanding.



7. RESULT ANALYSIS

Career selection has always been an important aspect in everybody's life. By using our project we have successfully ensured career recommendation to students. Career recommendation is the main highlight of our project. Another feature is suggesting colleges to students as per the recommendation. This application will help to solve the issues with the help of great technology and ideas.

8. CONCLUSION

The main aim of the project is to make students understand their strengths, personality and skills. With the help of a career guidance system, students can choose a career path by directly interacting with the online counsellor. Also, it will help them to follow their interest. This system lends a helping hand to 10th as well as 12th standard students. 10th standard students would be able to choose suitable streams for themselves. 12th standard students can select suitable fields of their choice. This process not only depends on career experts, but information that is provided by parents and their children. This process is also very important and helpful to build up children's careers

9. FUTURE SCOPE

As the Education system is emerging day by day due to the internet we can provide tutorials, learning videos, ebooks on our website. The scope of the website can be further expanded by providing guidance to Engineering students also our website will provide the list of colleges along with the cut offs and number of seats available. A chatbot can be used for interacting directly with the students. Video cameras and microphones can be used.

ACKNOWLEDGEMENT

We take the opportunity to express our sincere gratitude to our mentor **Mrs. Payal Sachdev** for the guidance, valuable inputs, continuous encouragement and cooperation throughout the work

REFERENCES

- [1] Lakshmi prasanna, 2DR.D.Haritha, "Smart Career Guidance and Recommendation System", IJEDR 2019.
- [2] Phagwat, Shraddha Detha, Sunny Chavan, "Career Guidance System using Machine Learning For Engineering", rof. Ranjan Singh, Ronit Pandita, Kaushik Kalyanaraman, Gursimran Singh Chhabra, "Career Guidance System", International Journal of Advanced Research in Computer and Communication Engineering IJARCCCE, Vol 7, February 2018
- [3] Shweta Kolekar, Mansi Surve, Pallavi Redkar, Sachin Bojewar, "A Review:E-Counseling", International Journal of Scientific Research in Computer Science, Engineering and InformationTechnology, IJSRCSEIT, Volume 3, Issue 3, ISSN : 2456-3307, 2018
- [4] Rucha Rangnekar, Khyati Pradeep Suratwala, Sanjana Krishna, Dr. Sudhir Dhage, "Career Prediction Model Using Data Mining And Linear Classification", IEEE2018..