



IoT Based Agricultural Crop Monitoring Sensors

Ms P.M.Mahadik¹, Samidha Sawant², Pratiksha Patil³, Aditya Jadhav⁴, Sumit Pawar⁵

Lecturer, E&Tc, AITRC, Vita, India¹

Student, E&Tc, AITRC, Vita, India²⁻⁵

Abstract: The Internet of things (IOT) is remodeling the agriculture enabling the farmers with the wide range of techniques. IOT technology helps in collecting information about conditions like weather, moisture, temperature and fertility of soil, Crop online monitoring enables detection of weed, level of water, pest detection, animal intrusion in to the field, crop growth, agriculture Wireless sensor networks are used for monitoring the farm conditions and micro controllers are used to control and automate the farm processes. To view remotely the conditions in the form of image and video, wireless cameras have been used. IOT technology can reduce the cost and enhance the productivity of traditional farming.

Keywords Component: Crop Monitoring, IOT project, Sensors, Smart Agricultural

I. INTRODUCTION

In 1995, “thing to thing” was coined by BILL GATES. In 1999, IoT (Internet of Things) was come up by EPC global. IOT interconnects human to thing, thing to thing and human to human. The goal of IOT is bring out a huge network by combining different types connected devices. IOT targets three aspects Communication, automation, cost saving in a system. IOT empowers people to carry out routine activities using internet and thus saves time and cost making them more productive. IOT enables the objects to be sensed and/or controlled remotely across existing network model. IOT in environmental monitoring helps to know about the air and water quality, temperature and conditions of the soil, and also monitor the intrusion of animals in to the field. IOT can also play a significant role in precision farming to enhance the productivity of the farm.

II. LITERATURE SURVEY

Balaji Banu [1] designed a wireless sensor networks to observe the conditions of the farming and increasing the crop yield and quality. Sensors are used to monitor different conditions of environment like water level, humidity, temperature etc., The processors ATMEGA8535 and IC- S8817 BS, analog to digital conversion and wireless sensor nodes with wireless transceiver module based on Zig bee protocol are used in the designing the system. Database and web application is used to retrieve and store data. In this experiment the sensor node failure and energy efficiency are managed.

Liu Dan [2], Joseph Haule, Kisangiri Michael [3] and Wang Weihong, Cao Shuntian [38] carried out experiments on intelligent agriculture greenhouse monitoring system based on ZigBee technology. The system performs data acquisition, processing, transmission and reception functions. The aim of their experiments is to realize greenhouse environment system, where the of system efficiency to manage the environment area and reduce the money and farming cost and also save energy. IOT technology here is based on the B-S structure and cc2530 used like processing chip to work for wireless sensor node and coordinator. The gateway has Linux operating system and cortex A8 processor act as core. Overall the design realizes remote intelligent monitoring and control of greenhouse and also replaces the traditional wired technology to wireless, also reduces manpower cost. Joseph haule [3], Dragoş Mihai Ofrim, Bogdan Alexandru Ofrim and Dragoş Ioan Săcăleanu [18] have proposed an experiment that explains the use of wsn used in automating irrigation. Irrigation control and rescheduling based on wsn are powerful solutions for optimum water management through automatic communication to know the soil moisture conditions of irrigation design. The process used here is to determine the proper frequency and time of watering are important to ensure the efficient use of water, high quality of crop detection delay throughput and load. Simulation is done for agriculture by OPNET. Another design of wsn is deployed for irrigation system using Zig bee protocol which will impact battery life. There are some drawbacks as wsn is still under development stage with unreliable communication times, fragile, power consumption and communication can be lost in agricultural field. so automate irrigation system and scheduling based on wireless sensor networks are used. WSN uses low power and a low data rate and hence energy efficient technology. All the devices and machines controlled with the help of inputs received via sensors which are mixed with soil. Farmers can analyze whether the system performs in normally or some actions are need to be performed.



III. METHODOLOGY



A. Existing System

Agriculture is the back bone of our Nation. In olden days farmers used to guess the fertility of soil and made assumption to grow which type of crop. They didn't know about the moisture, level of water and particularly weather condition which terrible a farmer more. They use pesticides based on some assumption which made lead a serious effect to the crop if the assumption is wrong. The productivity depends on the final stage of the crop on which farmer depends.

Drawbacks of Existing System

Productivity may or may not be more We cannot estimate weather conditions as pollution is increasing gradually etc.

B. Proposed System

To enhance the productivity of the crop there by supporting both farmer and nation we have to use the technology which estimates the quality of crop and giving suggestions. Wireless sensor network are sensors of different types are used to collect the information of crop conditions and environmental changes these information is transmitted through network to the farmer or devices that initiates corrective action. Some disadvantages in communication must be overcome by advancing the technology to consume less energy and also by making user interface ease of use.

IV. BLOCK DIAGRAM

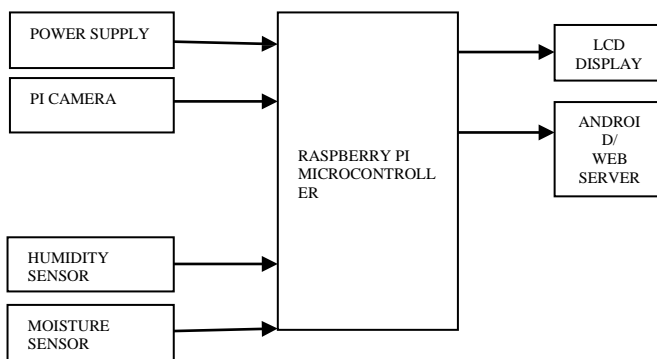

The main objective of this project is to design a smart Agriculture in order to monitor a crop growth. The system mainly consists with Raspberry-pi Microcontroller, Pi Camera, Humidity Sensor, Moisture Sensor, Temperature Sensor, Water level sensor along with LCD Display. Initially the system will collect all the parameters regarding the crop and displays in the LCD-Display similarly with the help of Pi camera the system will predict and analysis for animal intrusion and the same thing will be transmitting to the server.

analysis for animal intrusion and the same thing will be transmitting to the server.

A. Raspberry Pi Microcontroller

Raspberry Pi is a credit-card sized computer manufactured and designed in the United Kingdom by the Raspberry Pi foundation with the intention of teaching basic computer science to school students and every other person interested in computer hardware, programming and DIY-Do- it Yourself projects.

The Raspberry Pi is manufactured in three board configurations through licensed manufacturing deals with Newark element 14 (Premier Farnell), RS Components and Egoman. These companies sell the Raspberry Pi online. Egoman produces a version for distribution solely in China and Taiwan, which can be distinguished from other Pis by their red coloring and lack of FCC/CE marks. The hardware is the same across all manufacture rs.

The Raspberry Pi has a Broadcom BCM2835 system on a chip (SoC), which includes an ARM1176JZF-S 700 MHz processor, VideoCore IV GPU and was originally shipped with 256 megabytes of RAM, later upgraded (Model B & Model B+) to 512 MB. It does not include a built-in hard disk or solid-state drive, but it uses an SD card for booting and persistent storage, with the Model B+ using a MicroSD.

The Foundation provides Debian and Arch Linux ARM distributions for download. Tools are available for



Fig 1: Raspberry-Pi Module

Python as the main programming language, with support for BBC BASIC (via the RISC OS image or the Brandy Basic clone for Linux), C, Java and Perl.

A. Power Supply



Fig 2: Power Supply

The raspberry pi 3 is powered by a +5v micro USB supply.

B. Pi Camera



Fig 3: Pi Camera

In order to meet the increasing need of Raspberry Pi compatible camera modules. The ArduCAM team now released a revision C add-on camera module for Raspberry Pi which is fully compatible with official one. It optimizes the optical performance than the previous Pi cameras, and give user a much clear and sharp image. Also it provides the FREX and STROBE signals which can be used for multi-camera synchronize capture with proper camera driver firmware.

It attaches to Raspberry Pi by way of one of the two small sockets on the board upper surface.

This interface uses the dedicated CSI interface, which was designed especially for interfacing to cameras. The CSI bus is capable of extremely high data rates, and it exclusively carries pixel data. The camera is supported in the latest version of Raspbian.

C. Sensors

I. Moisture Sensor

Soil moisture sensors measure the water content in soil. A soil moisture probe is made up of multiple soil moisture sensors. One common type of soil moisture sensors in commercial use is a frequency domain sensor such as a capacitance sensor.

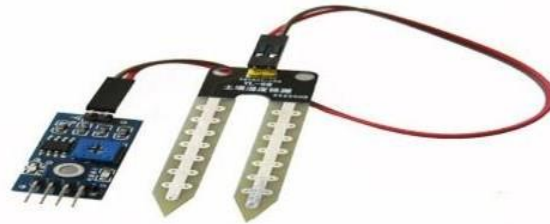

Fig 4: Moisture Sensor

Measuring soil moisture is important in agriculture to help farmers manage their irrigation systems more efficiently. Not only are farmers able to generally use less water to grow a crop, they are able to increase yields and the quality of the crop by better management of soil moisture during critical plant growth stages.

II. Temperature and Humidity Sensor

You can measure temperature more accurately than a using a thermistor.
 The sensor circuitry is sealed and not subject to oxidation, etc.

The LM35 generates a higher output voltage than thermocouples and may not require that the output voltage be amplified



Fig 5: Temperature and Humidity Sensor

III. Water level Sensor



Fig 6: Water level Sensor



Water level sensor are used to detect the level of substances that can flow.

It is used to indicate the optimize the level of water

Result and Implementation



Fig 7: Input image of diseased leaf Cassia Fistula and its conversion to grey scale.



Fig 8: Input image of diseased leaf cassia fistula and its conversion to gray scale



Fig 9: Input image of wet leaf Cassia Fistula and its grey scale Conversion.

V. CONCLUSION AND FUTUREWORK

Thus, the paper proposes an idea of combining the latest technology into the agricultural field to turn the traditional methods of irrigation to modern methods thus making easy productive, and economical cropping. Some extent of automation is introduced enabling the concept of monitoring the field and the crop conditions within some long-distance ranges using cloud services.

The advantages like water- saving and labor-saving are initiated using sensors that work automatically as they are programmed. This concept of modernization of agriculture is simple, affordable and operable.

- (i) Later, it can be interfered with HYDROPHONICS which is hydro-irrigation method (requires no soil) for complete transformation of phase of Irrigation.
- (ii) Every other person can monitor condition of the filed by working at their own places without being present in the field, thus encouraging agriculture.
- (iii) The camera module can be placed on a drone to capture huge number of fields at once by flying in the air both horizontally and vertically such that every look and corner of the plant is visible.

REFERENCES

- [1]. Balaji Bhanu, Raghava Rao, J.V.N. Ramesh and Mohammed Ali hussain, "Agriculture Field Monitoring and Analysis using Wireless SensorNetworks for improving Crop Production", 2014 Eleventh InternationalConference on Wireless and Optical Communications Networks(WOCN)
- [2]. LIU Dan, Cao Xin, Huang Chongwei, Ji Liang Liang, "Intelligent agentgreenhouse environment monitoring system based on IOT technology",2015 International Conference on Intelligent Transportation, Big Data &Smart City
- [3]. Joseph Haule, Kisangiri Michael, "Deployment of wireless sensornetworks (WSN) in automated irrigation management and schedulingsystems: a review", Science, Computing and Telecommunications(PACT), 2014, Pan African Conference



- [4]. S. Vijayakumar, J. Nelson Rosario, "Preliminary Design for Crop Monitoring Involving Water and Fertilizer Conservation Using Wireless Sensor Networks", Communication Software and Networks (ICCSN), 2011 IEEE 3rd International Conference.
- [5]. G. Nisha, J. Megala, "Wireless Sensor Network Based Automated Irrigation and Crop Field Monitoring System", 2014 Sixth International Conference on Advanced Computing (IcoAC).
- [6]. Meng Ji-hua, Wu Bing-fang, Li Qiang-zi, "A Global Crop Growth Monitoring System Based on Remote Sensing", 2006 IEEE International Symposium on Geoscience and Remote Sensing.
- [7]. Alan Mainwaring, Joseph Polastre, Robert Szewczyk, David Culler, John Anderson, "Wireless Sensor Networks for Habitat Monitoring", International Conference.
- [8]. Lei Xiao, Lejiang Guo, "The Realization of Precision Agriculture Monitoring System Based on Wireless Sensor Network", 2010 International Conference on Computer and Communication Technologies in Agriculture Engineering.
- [9]. Ling-ling LI, Shi-feng YANG, Li-yan WANG, Xiang-ming GAO, "The Greenhouse Environment Monitoring System Based on Wireless Sensor Network Technology", Proceedings of the 2011 IEEE International Conference on Cyber Technology in Automation, Control, and Intelligent Systems, March 20-23, 2011, Kunming, China.
- [10]. Chun-ling Fan, Yuan Guo, "The Application of a ZigBee Based Wireless Sensor Network in the LED Street Lamp Control System", 2013, College of Automation & Electronic Engineering, Qingdao University of Scientific & Technology, Qingdao, China embedded technology, Consumer Electronics - China, 2014 IEEE International Conference.
- [11]. FuBing, "Research on the Agriculture Intelligent System Based on IOT", 2012 International Conference on Image Analysis and Signal Processing.
- [12]. Wen-Yao Zhuang, Miguel Costa Junior, Pedro Cheong, Kam- Weng Tam, "Flood Monitoring of Distribution Substation in Low- Lying Areas Using Wireless Sensor Network", Proceedings of 2011 International Conference on System Science and Engineering, Macau, China – June 2011 (NESEA), 2012 IEEE 3rd International Conference.