



# A SMART HOME- IoT-BASED HOME AUTOMATION SYSTEM

Gunit Choubisa<sup>1</sup>, Lalit suthar<sup>2</sup>, Dr. Ajay Kumar Sharma<sup>3</sup>

UG Scholar Department of CSE, GITS, Udaipur<sup>1, 2</sup>

Associate Professor & M. Tech Coordinator, Department of CSE, GITS, Udaipur, India<sup>3</sup>

**Abstract:** The modern home automation system gives security and blissful life at residence. That is why the popularity of using home automation technology is increasing day by day. This paper proposed the design and implementation of home automation, monitoring, and home security through the internet of things (IoT). This system focuses on the residence to make a smart wireless home security system that sends an email with a picture to the homeowner if any trespass enters into the residence and also gives an alarm if any fire accident happened. This system can control and monitor the house temperature, humidity, flame condition and all home devices from anywhere in the world. To update data our system takes just 3 seconds. As a result, a concern person can take necessary steps rapidly. This system can be controlled via many ways like the Internet, smartphone, voice control and electrical switch. Our proposed method has a small cost design, user flexible interface and simple installation in a house. Through IoT technology, the user can minimize the wastage of electrical power by proper monitoring and controlling.

**Index Terms:** Raspberry-pi 3 model B+, Home Automation, Web Server, Internet of Things.

## I. INTRODUCTION

The modern age is the age of technology and technology is never finishing process. Technology is advancing continuously and making our life easier, safer and comfortable. A home furnished with heating, lighting and electronic devices that can be controlled and monitored remotely by computer or smart-phone is called a smart home. In our busy lives, it is very tough to keep an eye on security but with a smart home system, it becomes very simple. This system can give alert automatically if anyone breaks in. Different types of control systems have been using various studies on home automation systems such as Bluetooth, GSM, Internet, and Speech controlled wireless interactive home automation system. [1], It has been introduced Machine to Machine system using a global system for mobile communication. Speech controlled automation system has been proposed in [2], [3]. To control home appliances Bluetooth concept is suitable. Though these systems don't work remotely.

A cheaply cost Java-based house automation process has been described in [4]. In [5], A Zig Bee Based system has been introduced in detail. The most favorite home automation system in the international market is an internet-based home automation system [6]. The installation cost decreases and increases system flexibility through wireless-based home automation and monitoring systems [7]. According to homeowner lifestyle internet of things can observe, lead and handle the home conditions [8]. On the establishment of communication infrastructure speed of communication, data transmission reliability, cyber-security and enhance hardware development have been focused on most of the research in a smart home [9]. In [10], the paper has been presented vision, application and research challenges of the internet of things. The developed system has mainly three parts that are monitor, control and security parts. The devices of the home can be monitored and controlled by different systems. Through the internet the automation system can send and receive data from the remote user by online or offline. The user can control and monitor the status concerning On/OFF of the devices of the home. The homeowner can observe the house temperature, humidity, and flame condition from anywhere and anytime by using a smart-phone or desktop or laptop. If any trespasses enter into the house gate camera take a picture automatically and send the picture to the homeowner through email.

### 1.1 INTERNET OF THINGS

IoT means the Internet of Things. It is very tough to define IoT precisely. The topic IoT has been used by Kevin Ashton who is an expert on digital innovation. Then it became very popular. IoT is a network of internet-linked action capable of gather and barter of data or information. Many computing devices are embedded with our necessary appliances to the internet through IoT.

IoT term has two major parts:

- Internet is the backbone of connectivity
- Things meaning objects

The term internet of things is a concept but it is not specific hardware or software or electronics. With the introduction of IoT, The home automation systems are becoming more famous at present days research. Most of the devices are monitored and controlled for the people. Through the internet of things, it is possible to control and monitor home appliances.



With the internet of things, the physical world is becoming one big information systems. To enhance the living value of our life IoT technology is used to get novelty concepts.

## 1.2 ADVANTAGES OF OUR SYSTEM

- The system is cost-effective and flexible, when compared to CCTV or other methods.
- To update data to the server our system takes just 3 seconds.
- Disable persons can control home appliances through voice control.
- Control from anywhere in the world through the internet.
- It works wirelessly.
- It ensures home security.
- Comfort and luxury.

This paper is presented in the following sequences. The proposed system is given in section 2. System design is given in Section 3. The implementation set up is given in Section 4. The work is summarized in Section 5.

## II. PROPOSED METHOD

There are no users who don't want to add more features over the existing system which gives more elasticity and runs with few general applications like a smart-phone. Our system is designed in such a way that abstains from the drawbacks of the existing system. The developed method gives more security, comfort, and flexibility. The aim of our proposed method is to design and to implement a low cost and open-source home automation that's able to lead most of the home and sustain the home automation system. To use wireless reliable technology to interconnecting many modules to the server of the home automation system, as a result, the proposed system gives more flexibility. This system will reduce the expansion cost; will add to the elasticity of advancement. Figure 1 shows the block diagram of our proposed method.

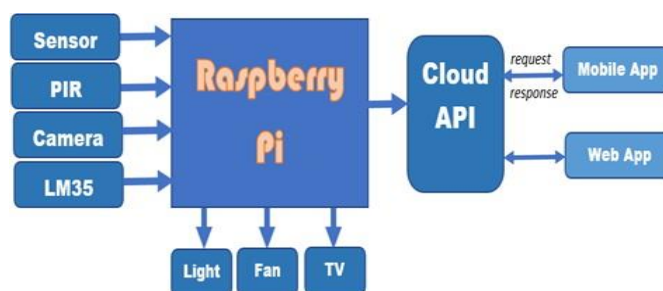

Fig. 1. Proposed Solution

## III. SYSTEM DESIGN

### 3.1 RASPBERRY PI

A Raspberry-pi is a cheap cost deposit the card-shaped sole board computer that is invented by Pi foundation. It's like a brain. Its primary advantage is processing higher level processing capability. The main part of the home automation system is Raspberry Pi. Raspberry-pi three model B plus is used by us. To improve students programming skills and hardware understanding raspberry-pi is very helpful.

### 3.2 SENSOR AND CAMERA INTERFACING

The Passive Infrared sensor module is used for motion detection. For easy operation, a PIR sensor is used. PIR sensor detects a human being moving around within approximately 10m from the sensor. For experimental purpose LM35 basic temperature sensor is used. LM35 sensor detects room temperature. A flame sensor is used to detect where a gas valve is open and the fire is present. A humidity sensor or hygrometer senses, measures and reports both moisture and temperature. Cameras are attached at the gate for security purpose which takes the picture and sends to homeowner email through the internet.

### 3.3 ARCHITECTURE OF PROPOSED IOT SYSTEM

The proposed IoT architecture system consists of Network and Transport Layer, data link Layer, Application and Presentation layer, Physical Layer. IoT gateway router, device manager and many contact protocols are the part of the data link layer. All the controlling devices are included in the physical layer section. For controlling many devices a web portal is designed a web page at the application and presentation layer. The devices can also be controlled by making an app on a mobile phone. The web portal and mobile app do similar works. The proposed system IoT layer is shown in figure 2.

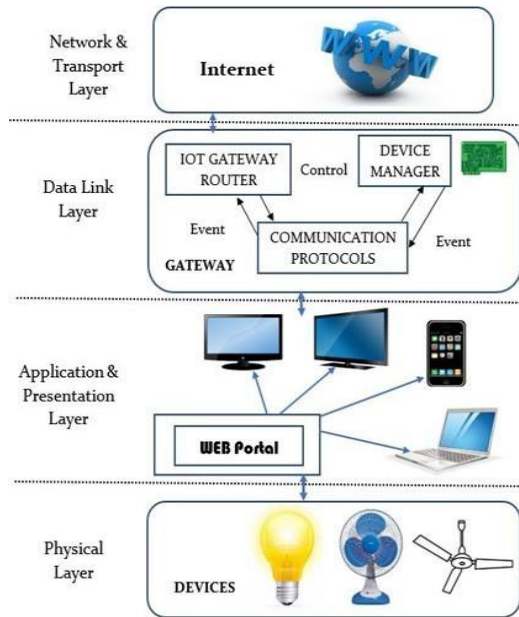

Fig. 2. Proposed Solution of IoT layer

IV. IMPLEMENTATION

To examine the architecture of our proposed technique, a prototype has developed that is checked in our laboratory. The implementation part is mainly divided into two parts. One is the hardware part and another is the software part. The implementation part is described in details as follows,

4.1 HARDWARE IMPLEMENTATION

The major components of hardware parts are a Raspberry pi 3, Camera, PIR sensor, LM35 sensor, Flame sensor, Humidity sensor, Relay Bank. Many sensors are interfaced with Rasp- berry-pi through Python programming language and the output is seen in Web and Android App. In figure 3, the circuit diagram is shown.

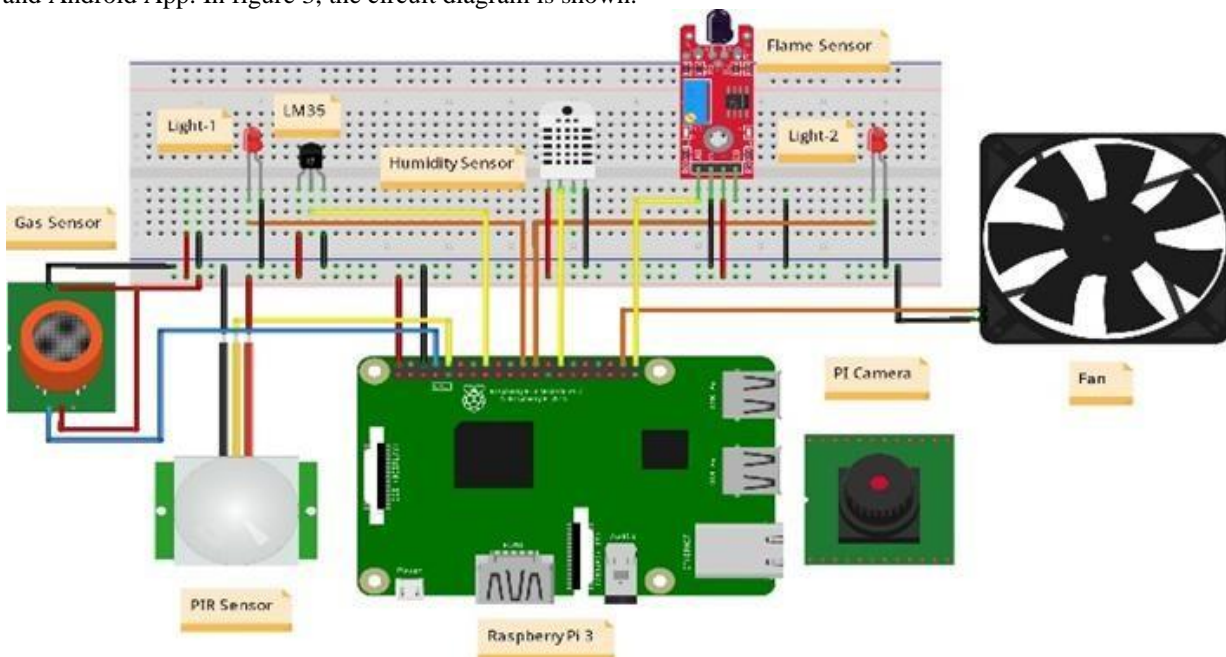

Fig. 3. Circuit diagram of Interfaces with many sensors



## 4.2 SOFTWARE IMPLEMENTATION

Configure the Raspberry Pi. Then, we write a code using Python programming language to remotely control lights, fan, television, refrigerator, and other home appliance. In figure 4, the demo code is shown.

```

homeautomation.ino
45 void loop() {
46
47 // Temperature measurement
48 temperature = dht.getTempCelcius();
49
50 // Humidity measurement
51 humidity = dht.getHumidity();
52
53 // Light level measurement
54 float light_measurement = analogRead(light_sensor_pin);
55 light = (int)(light_measurement/4096*100);
56
57 int uvValue=analogRead(uv);
58 ultraviolet = (uvValue*100)/4023;
59 unsigned long now = millis();
60 Particle.function("led",ledControl);
61 //Every 5 seconds publish uptime
62 if (now-lastTime>5000UL) {
63 lastTime = now;
64 sprintf(publishString,{"Temperature": %u, "Humidity": %u, "Light": %u},temperature,humidity,light);
65 Particle.publish("Uptime",publishString);
66
67 }
68
69 }
70 int setPosition(String posValue) {
71 pos = posValue.toInt();
72 Serial1.printf("%u", pos);
73 return 0;
74 }
75 int ledControl(String command) {
76 int state =0;
77 int pinNumber = (command.charAt(1)-'0') - 1;
78 if(pinNumber < 0 || pinNumber > 7) return -1;
79 if(command.substring(3,7) == "HIGH") state = 1;
80 else if(command.substring(3,6) == "LOW") state = 0;
81 else return -2;
82
83 digitalWrite(pinNumber,state);
84 return 1;
85 }

```

Fig. 4. Demo code

This paper use the third-party server as Adafruit for this proto- type but for the business purpose we use our server. We connect the code between Raspberry Pi and the third-party live server. The Raspberry-pi is interfaced with many sensors such as LM35 sensors, Flame sensors, Humidity sensors, PIR sensors. These sensors are continuously updated data to the server after 3 sec left. This can easily change by the user. To develop an Android app using Android Studio to control and monitoring home appliances. First, the android app connected the server and sends data to the server from the user mobile phone via the internet when the user presses the visual button in this android app. Raspberry pi reads the data from the server and executes this instruction. Also, the Android app gets updated JSON data from the live server and displayed on the mobile screen. For security purpose, we interface Raspberry Pi with a camera to detect human and send a mail to the owner using Open CV and SMTP module

## 4.3 CONTROL VIA MOBILE APPLICATION

Smart-phone can be accessed on the home automation system through IP addresses. Wwww.io.adafruit.com is a hosted server of the smart-phone and the remote user sends and receives data through this server. Through a smart-phone and IP address, the user can check the status and instruct the devices. We have developed a web portal that can also control and monitor the devices. To enter the system an authentication user id and password are required that protected the unauthorized user and ensure security. When we successfully completed our authentication then we are able to visible the status of the light, fan, TV, and refrigerator in each of the rooms where they are turned ON/OFF. We are able to see all the devices and we can select any devices which we want to control. Figure 5 shows the controlling app, control devices and their status (on/off/temperatures).

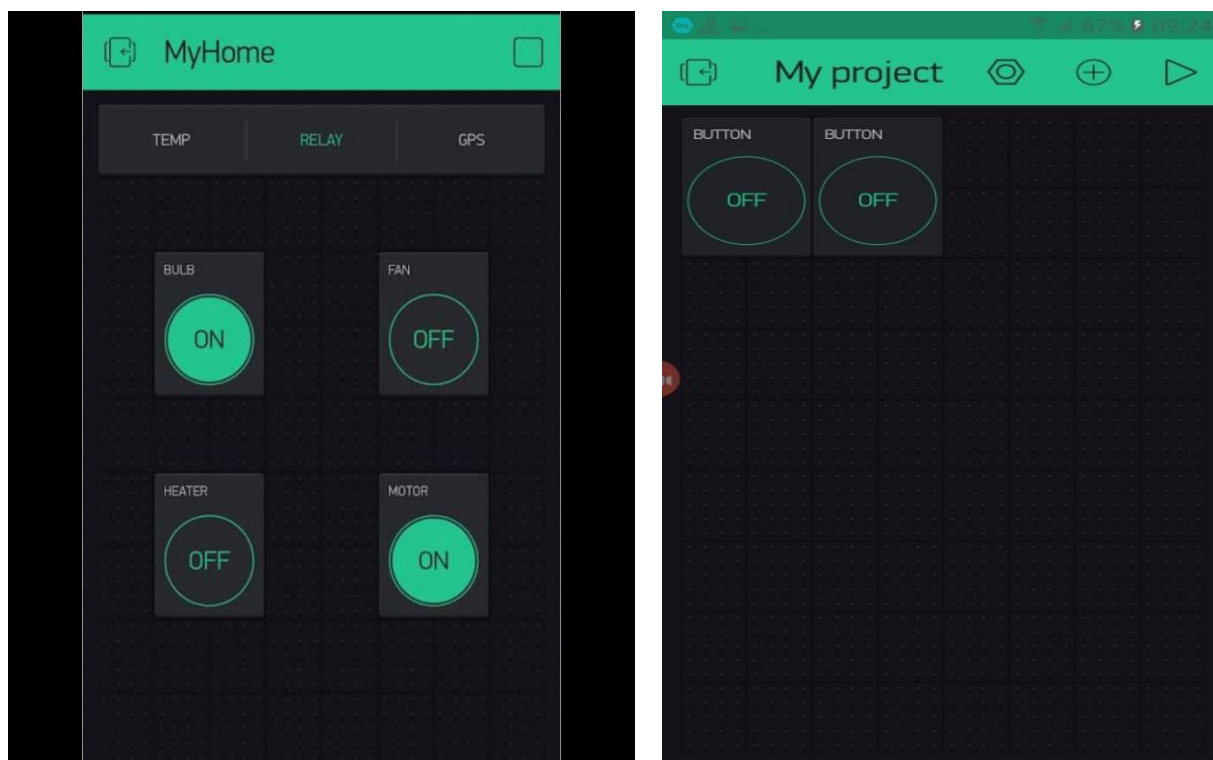

Fig. 5. Controlling app home page and List of appliances and controlling option

By using the IoT technology the control and monitor of the devices can be done.

**4.4 SECURITIES**

This study ensured their home automation system devices security through user id and password system and it has used pi-camera to detect trespass in our residence, offices or workplaces in absence of the owner. When trespass enters into the house or office, the pi-camera detect the trespass face and take pictures through open CV and store into SD card, then use the SMTP Python library sends email automatically to real-time concern person. To send an email to any Internet machine with an SMTP or ESMTP listener daemon via the smtplib module defines an SMTP client session object.

**4.5 COMPARISION WITH EXISTING SYSTEM**

This proposed method compared the updating data time, cost, controlling methods, circuit complexity, image quality and integration of images quality with many existing methods and showed that our proposed system has a better result than the existing systems. The table 1 shows the comparison with existing systems.

TABLE 1 COMPARE WITH EXISTING SYSTEM

Serial No.	Parameters	Existing System	Proposed System
1	Data update time	Didn't mention	Only 3 sec
2	Control method	Internet, Electrical Switch, GUI	Internet, Electrical Switch, Voice control App
3	Circuit complication	Complex	Convenient
4	Image quality	Low	High
5	Integration of appliances	Less	High



## V. CONCLUSION

There have been many works done by the existing method on home automation and security purposes. But our method is unique when you compare with existing method cost, security, and sustainability. Our proposed method gives data up- dates within 3 seconds that help to take a quick decision if any hazard occurs. This system can be controlled via many ways like Voice control app, Smart-phone, internet, World Wide Web, and electrical switch that help all kinds of peoples (Specially disable persons) to control home appliances. Through IoT technology, our system can ensure security and comfort for all users. The Pi-camera sends an email automatically intruder picture or fire accident to concern person that enhances the safety of the residence and the homeowner can alert as well as can take necessary steps toward his family safety which is not possible by CCTV. This system can be used for mitigating the wastage of electrical power by proper scheduling and monitoring of the devices. The developed system can be engaged in many places such as banks, hospitals, labs, offices, etc that dramatically cut back the hazard of unauthorized entry. This method reaction is excellent which is sustain- able for long time performance. It has to further work on live video streaming.

## REFERENCES

- [1] A. Alheraish, —Design and Implementation of Home Automation System, IEEE Trans. Consum. Electron., vol. 50, no. 4, pp. 1087– 1092, 2004.
- [2] H. Jiang, Z. Han, P. Scucces, S. Robidoux, and Y. Sun, —Voice- activated environmental control system for persons with disabilities, Bioeng. Proc. Northeast Conf., pp. 167–168, 2000.
- [3] A. R. Al-Ali and M. Al-Rousan, —Java-based home automation system,IEEE Trans. Consum. Electron., vol. 50, no. 2, pp. 498–504, 2004.
- [4] S. I. Azid and S. Kumar, —Analysis and performance of a low cost SMS based home security system, Int. J. Smart Home, vol. 5, no. 3, pp. 15–24, 2011.
- [5] H. ElKamchouchi and A. ElShafee, —Design and prototype implementation of SMS based home automation system,Int. Conf. Electron. Devices, Syst. Appl., pp. 162–167, 2012.
- [6] J. Pan, R. Jain, S. Paul, T. Vu, A. Saifullah, and M. Sha, —An Internet of Things Framework for Smart Energy in Buildings: Designs, Prototype, and Experiments,IEEE Internet Things J., vol. 2, no. 6, pp. 527–537, 2015.
- [7] D. Li, Z. Aung, J. Williams, and A. Sanchez, —P3: Privacy preservation protocol for automatic appliance control application in smart grid,IEEE Internet Things J., vol. 1, no. 5, pp. 414–429, 2014.
- [8] A. Rajandekar and B. Sikdar, —A survey of MAC layer issues and protocols for machine-to-machine communications,IEEE Internet Things J., vol. 2, no. 2, pp. 175–186, 2015.
- [9] W. Shi, J. Cao, Q. Zhang, Y. Li, and L. Xu, —Edge Computing: Vision and Challenges, IEEE Internet Things J., vol. 3, no. 5, pp. 637–646, 2016.
- [10] A. Maru, A. K. Sharma and M. Patel, "Hybrid Machine Learning Classification Technique for Improve Accuracy of Heart Disease," 2021 6th International Conference on Inventive Computation Technologies (ICICT), Coimbatore, India, 2021, pp. 1107-1110, doi: 10.1109/ICICT50816.2021.9358616.
- [11] Taunk, D., Patel, M. (2021). Hybrid Restricted Boltzmann Algorithm for Audio Genre Classification. In: Sheth, A., Sinhal, A., Shrivastava, A., Pandey, A.K. (eds) Intelligent Systems. Algorithms for Intelligent Systems. Springer, Singapore. [https://doi.org/10.1007/978-981-16-2248-9\\_11](https://doi.org/10.1007/978-981-16-2248-9_11)
- [12] Ankita, S., Mayank, P. & Manish, T. (2019). A comparative study to detect fraud financial statement using data mining and machine learning algorithms. International Research Journal of Engineering and Technology (IRJET), 6(8), 1492-1495.
- [13] J. S. Donnal, J. Paris, and S. B. Leeb, —Energy Applications for an Energy Box, IEEE Internet Things J., vol. 3, no. 5, pp. 787–795, 2016.