

Smart Grid Stability Analysis using Neural Network

Herald Leo L¹, Arikrishna A², Dr.DNS. Ravikumar³

Student, Department of Electrical and Electronics Engineering, Sathyabama Institute of Science and Technology^{1,2}

Associate Professor, School Of Electrical and Electronics, Sathyabama Institute of Science and Technology³

Abstract: Fossil fuel reserves draining at an alarming rate, and rising day by day environment-related problems made the world find green energy reserves. One among such a type of solution has been in view of abundant availability, stability of the solar power by which photovoltaic system was decreased in terms of cost. This paper describes the development of a solar energy management system using a Single-Ended Primary Inductor Converter - based DC-DC converter and a three - phase Inverter for grid - interfacing application. The ANN-based regulation will enable dynamic regulation of the real and reactive power course across the system to facilitate efficient energy transfer and maintain stability of the grid. Furthermore, the performance of the system can be validated from simulation studies about its capability toward efficiency, power factor correction and adaptability to change in solar intensity and grid.

Keywords: Solar Power Energy Management, SEPIC Converter, Three - Phase Inverter, Artificial Neural Network(ANN),Grid Stability

1. INTRODUCTION

Smart grid stability analysis traditionally operating fossil fuel reverse at a rate more alarming, and rising day by day environment-related problems made the world find renewable energy resources. One among such a type of solution has been in view of abundant availability, reliability of the solar energy by which photovoltaic system was decreased in terms of cost. The integration of such energy generation system into conventional power grids creates urgent problems such as variability in formation and grid instability intelligent energy management systems.

Smart grid have been on the rise in this new age of combination green energy into our existing conventional grids. The concept of smart grid deals with the combination of sensors and actuators to collect the data required. This makes the process of monitoring and processing the output of the grid easier and efficient. The introduction of smart grid system proved to be effective to smoothly connect the green energy production to the grid. This paper used an Artificial Neural Network algorithm which was used to control a three phase inverter. This three phase inverter is combined with a Single Ended Primary Inductor Converter which boosts the DC current that is obtained as an output from the solar panel. The solar panel represents the integration of green energy into the grid. The Artificial Neural Network is combined with the three phase inverter and the output is synchronized with the grid.

Increased demand for renewable energy, particularly solar energy, has also posed additional challenges in terms of grid stability owing to its nature of intermittency. Various solutions have been put forward to address this challenge. A technique for networked control via Phasor Measurement Units(PMUs) stabilizes power system oscillations and provides smart grid stability even in case of data loss[1]. AGC stability is enhanced with Cognitive Radio(CR) networks to operate under changing conditions more effectively[2]. Stable controllers have been suggested to solve smart grid delay and disturbance[3]. Voltage stability indices are intended for black start prevention and generator stability enhancement[4], whereas distributed generation system indices are voltage collapse resistant and grid stability enhancing[5]. Power balance and integration of renewable resources such as train regenerative braking are ensured through nonlinear control methods in DC Micro-grids, especially in smart train stations[6]. Through predictive analysis, the Multi-directional Long Short-Term Memory(MLSTM) techniques is superior to traditional techniques such as LSTM and RNNs[7] in grid stability prediction. Artificial Neural Networks(ANNs) are also employed for system reliability as well as energy distribution optimization[8]. Explainable AI(XAI) and analytic further enhance Decentralized Smart Grid Control(DSGC) through optimal maximum energy management via deep learning as well as gradient boosting[9]. Hybrid AI models were beneficial in terms of improving stability, solar forecast, fault identification, and load balance in smart grid[10].

2. PROPOSED SYSTEM

The proposed system contain of a SEPIC(Single Ended Primary Inductor Converter) it is a DC-DC boost converter which amplifies the voltage result produced by a solar panel.

This amplified DC voltage is provides as input to the inverter. The Inverter is combined which uses ANN algorithm.This result is synchronized with the grid.The system integrates a SEPIC(Single Ended Primary Inductor Converter)DC-DC converter and 3-phase inverter,which is managed with the help of an Artificial Neural Network(ANN)-based device.The SEPIC converter stabilizes UPS and downs from solar panels,ensuring a regular voltage for the inverter. The 3-step inverter then converts this regulated DC to AC,which enables the seamless grid connection.

ANN-based fully managed devices increases real-time power management,adjusting active and reactive power,mainly going with flow depending on solar technology and grid conditions. Unlike traditional PI controllers,which lead to war with slow response time and non-linearity,the ANN model provides adaptive,high-accurate control,which definitely has stable voltage,better energy excellence,and more desirable grid synchronization.

Major equations

1.SEPIC Converter Output Voltage

$$V_0 = (D/(1-D))*V_{in}$$

Where:

V₀ = Output Voltage

V_{in} = Input voltage from PV panels

D = Duties cycle of SEPIC converter

2.Real and Reactive Power in Grid Integration

$$P = VI \cos(\theta)$$

$$Q = VI \sin(\theta)$$

Where:

P = Real strength

Q = Reactive energy

V = Voltage

I = Present

θ = Power attitude

3.ANN-Based Control Load Update Rules

$$W_{new} = W_{old} + \eta(\partial E / \partial W)$$

Where:

W_{new} = Updated weight in N-version

W_{old} = Previous weight

E = Error characteristic

By taking advantage of ANN based control,the system optimizes power delivery,ensuring grid balance,rapid response to variations, and improved utilization of solar energy. Fig 2.1 Shows Block Diagram of the Proposed System.

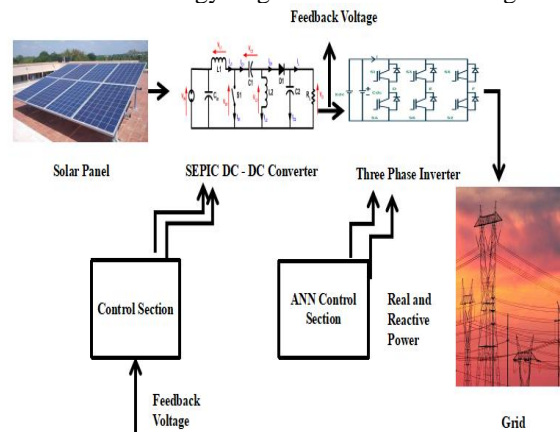

Fig 2.1 Block Diagram Of the Proposed System

2.1. METHODOLOGY

The proposed power management system is a SEPIC DC-DC converter connected to a three-phase inverter. Such fluctuating output from PV panels is transformed into AC power controlled, fitting the needs of the grid. It is stabilized as a constant DC voltage through the use of the SEPIC converter. Such fluctuating result from PV pans is then turned into AC through an inverter. This way the power flow is dynamically managed by the ANN-based control system, since it adjust real and reactive powers according to real-time grid conditions. This allows for optimal power delivery while keeping its quality as well as grid stability.

This project's approach involves creating a solar-powered energy control system. It combines a SEPIC DC-DC converter with a three-phase inverter to connect to the grid. The SEPIC converter controls the changing DC voltage from solar panels. This ensures a steady DC output. The inverter then changes this DC to AC for smooth grid connection. The system uses an Artificial Neural Network(ANN) control system to manage real reactive power and keep the grid stable. We simulate the system to check how it works. We look at the system's efficiency, power factor correction and it's response to the change in sunlight and the grid conditions. We compare the ANN controller's performance with standard PI controllers. This shows improvement in response time, voltage stability and power quality. We test the system in a simulated smart grid setting. This proves it works well to improve solar energy integration, manage power flow, and support overall grid stability. This update makes things clearer, gets rid of clunky wording, and keeps the technical details spot-on. Give me a shout if you want me to tweak anything else.

2.2 SIMULATION

The proposed system is imitated in a MATLAB/Simulink environment to validate the performance of the ANN-based control strategy. The simulation model includes a SEPIC DC-DC converter, a three-step inverter and a 3-phase power control system to regulate energy flow. To compare ANN-based controller with a traditional PI controller in terms of purpose:

Response Time : ANN controller displays rapid response to changes in solar radiation and grid conditions, ensuring real-time power management.

Voltage Stability : The ANN-based system maintains a more stable output voltage under fluctuations in input conditions compared to PI controller.

Power Quality : Simulated results reduce the harmonics and improve the power factor, which increases grid compatibility.

Wave Analysis

The simulation wave reflects its synchronization with a three-phase voltage output and grid ANN-based controlled effectively reduces oscillations and stabilizes power generations even during variation in solar input. The reaction time of the ANN-Controlled system is much lower than the PI-Controller system, which ensures better efficiency in dynamic conditions.

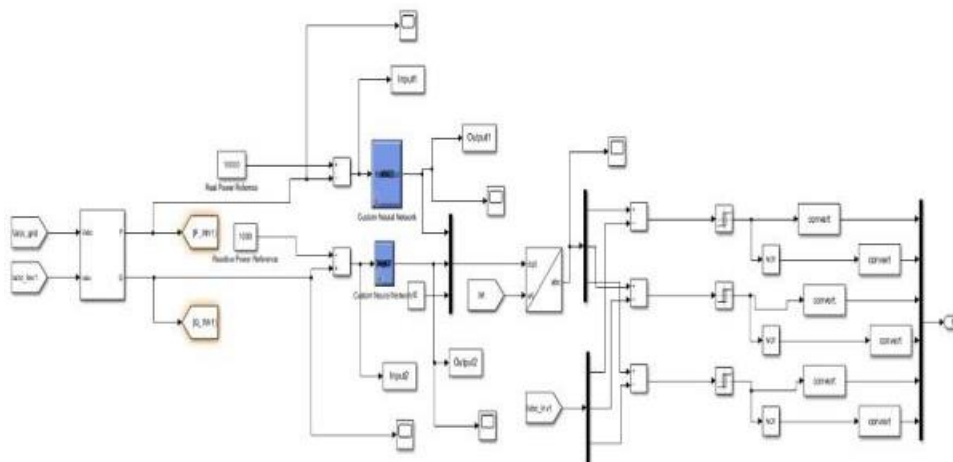

Fig 2.2.1 Simulation of Proposed System

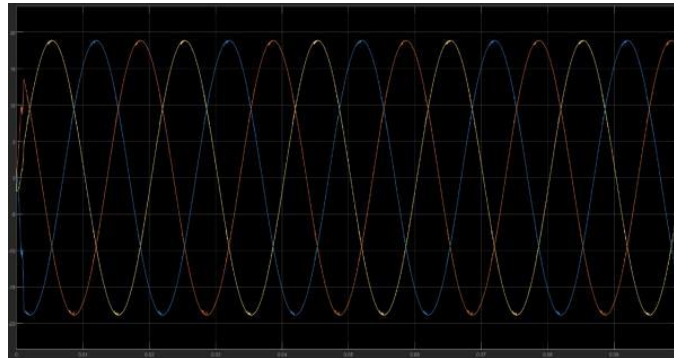

Fig2.2.2 Simulation output

Performance Comparison

Through a comparative analysis, it has been observed that the ANN-based controller improves the traditional PI controller by improving voltage regulation, reducing transient disturbances and obtaining efficient power distribution. The proposed system is suitable for smart grid applications where rapid adaptations is important to change power demands. The simulation results validate the effectiveness of the ANN-based system, providing the ability to adapt solar energy integration and ensure stable grid operations. Fig 2.2.1 & fig 2.2.2 Shows simulation and the result of proposed system.

3. RESULT AND DISCUSSION

We tested our smart grid stability system, which integrates a SEPIC DC-DC converter, a three-phase inverter, and an Artificial Neural Network(ANN) for real-time control. The goal was to manage power flow effectively, keep voltage levels stable, and ensure smooth grid synchronization. Our findings showed that the ANN-based controller outperformed traditional methods in several key areas.

To check the performance of the system we ran the simulation in MATLAB/Simulink platform compared the ANN-based control with a conventional PI controller.

The result we observed:

1. Response for changes

During the fluctuations in solar power the PI controller lagged but the ANN-based system adapted instantly. In real-time learning, the ANN quickly optimized power flow, reducing energy loss and fluctuations.

2. Voltage Output

Even while solar input varied, the SEPIC converter paired with the ANN will provide a stable voltage supply. Consistent voltage is maintained in ANN so it differs from the PI controller as it shows voltage fluctuations.

3. Power Quality

The grid will receive efficient energy transfer as the system improves power factor correction (PFC). The ANN will maintain smooth grid integration, prevent power distributions even when solar energy levels change.

Feature	ANN-based System	PI-Based System
Response Speed	Faster and adaptive	Slower response time
Voltage Stability	Consistently maintained	Prone to fluctuations
Power Factor Correction	High efficiency	Low efficiency
Adaptability to Solar Variations	Dynamic and real-time adjustments	Struggles with rapid changes
Grid Synchronization	Seamless and stable	Occasional inconsistencies

Fig 3.1 Comparison: ANN vs. PI Controller

Fig 3.1 Shows comparison of ANN to PI controller. Our findings demonstrate the advantages of ANN use for smart grid stability. Inefficiencies result from traditional PI controller’s inability to keep up with the quick fluctuations in solar power. In contrast, the ANN learns and adapts continuously, guaranteeing improved energy management, lower losses, and a more stable grid.

Our findings demonstrate that an ANN-based control system significantly improves the stability of the smart grid. It maintain grid stability while reacting more quickly, controlling voltage more skillfully, and enhancing electricity quality. Through intelligent, real-time modifications, this system offers a useful and effective means of incorporating solar energy into contemporary grids.

4. CONCLUSION

Our system successfully integrates a 12v battery which is boosted to 24v using a SEPIC converter this boosted voltage is showing on an LCD screen and analyzed using a CRO(Cathode Ray Oscilloscope) to obtain waveform characteristics the 24v output is then compared with the grid voltage post-transformer and synchronization is achieved using a SEPIC inverter and ANN algorithm the developing of ANN-based control system in smart grid has demonstrated improved efficiency voltage stability and power quality unlike traditional PI controller which struggle with rapid fluctuations in solar power the ANN model adapts in real-time stable energy flow and grid synchronization this system not only enhance overall energy but also support the application of renewable energy into modern grids with increasing demand for clean energy ANN-based smart grid management presents a real-time solution for reducing losses authenticating power distribution and maintaining grid stability further work can be focus on refining ANN models and testing their performance in real-world problems to be evaluating for enhance efficiency stability and reliability-our system successfully integrates 12v battery which is boosted to 24v using SEPIC converter this boosted voltage is showing on an LCD screen and analyzed using a CRO(Cathode Ray Oscilloscope) to obtain waveform characteristics the 24v output is then compared the grid voltage post-transformer and synchronization is achieved using a SEPIC inverter and ANN algorithm the developing of ANN-based control system in smart grids has demonstrated improved efficiency voltage stability and energy quality unlike traditional PI controllers which struggle with rapid fluctuations in solar power the ANN model adapts in real time stable energy flow and grid synchronization this system not only enhances overall energy but also supports the application of renewable energy into modern grids with increasing demand for clean energy ANN-based smart grid management presents a real-time solution for reducing losses authenticating power distribution and maintaining grid stability future work can be focus on refining ANN models and testing their performance in real-world problems to be evaluating to enhance efficiency.

REFERENCES

- [1] Singh, Abhinav Kumar, Ravindra Singh, and Bikash C. Pal. "Stability analysis of networked control in smart grids." *IEEE Transactions on Smart Grid* 6.1 (2014): 381-390.
- [2] Liu, Shichao, Peter X. Liu, and Abdulmotaleb El Saddik. "Modeling and stability analysis of automatic generation control over cognitive radio networks in smart grids." *IEEE Transactions on Systems, Man, and Cybernetics: Systems* 45.2 (2014): 223-234.
- [3] Ayar, Muharrem, et al. "A distributed control approach for enhancing smart grid transient stability and resilience." *IEEE Transactions on Smart Grid* 8.6 (2017): 3035-3044.
- [4] Samanta, Shouvik Kumar, and Chandan Kumar Chanda. "Investigate the impact of smart grid stability analysis on synchronous generator." 2017 IEEE Calcutta Conference (CALCON). IEEE, 2017.
- [5] Kumar Samanta, Shouvik, and Chandan Kumar Chanda. "Smart grid stability analysis on smart demand load response in coordinated network." 2018 2nd International Conference on Power, Energy and Environment: Towards Smart Technology (ICEPE). IEEE, 2018.
- [6] Perez, Filipe, et al. "Stability analysis of a DC microgrid for a smart railway station integrating renewable sources." *IEEE Transactions on Control Systems Technology* 28.5 (2019): 1802-1816.
- [7] Alazab, Mamoun, et al. "A multi-directional LSTM model for predicting the stability of a smart grid." *IEEE Access* 8 (2020): 85454-85463.
- [8] Mohsen, Saeed, et al. "Efficient artificial neural network for smart grid stability prediction." *International Transactions on Electrical Energy Systems* 2023.1 (2023): 9974409.
- [9] Ucar, Ferhat. "A comprehensive analysis of smart grid stability prediction along with explainable artificial intelligence." *Symmetry* 15.2 (2023): 289.
- [10] Akhter, Nur Farhana, Arif Mia, and Md Jakaria Talukder. "Python-Based Hybrid AI Models For Real-Time Grid Stability Analysis In Solar Energy Networks." *Frontiers in Applied Engineering and Technology* 1.01 (2024): 139-156.