



# IoT-Based Smart Wheelchair with GPS Tracking, Emergency Alert, and Multi-Mode Control System

Mr. M.V.J.T. ARUN, M. Tech <sup>1</sup>, K. HARISH <sup>2</sup>, K. JOHN BENNY <sup>3</sup>, M. SURYAKIRAN<sup>4</sup>,  
MD. NOUSHAD ALAM ANSARI<sup>5</sup>, M. THARUN BALAJI<sup>6</sup>

Assistant Professor, Mechanical Engineering, WELFARE Engineering College, Visakhapatnam 531173, India<sup>1</sup>

BTECH Student, WELFARE Engineering College, Visakhapatnam 531173, India<sup>2-6</sup>

**Abstract:** This project presents the design and development of an intelligent IoT-based smart wheelchair system that enhances mobility, safety, and communication for physically challenged individuals. The system integrates advanced technologies such as Wi-Fi-enabled control using ESP8266, real-time GPS tracking, emergency alert functionality, and multi-mode operation including joystick and voice control.

A key feature of the system is its assistive communication capability. Dedicated push buttons are provided for the user, which when pressed, generate predefined voice outputs such as “food”, “water”, “washroom”, etc. This feature is especially useful for users who are unable to speak or communicate easily, allowing them to convey their basic needs effectively.

The wheelchair is equipped with a GPS module that continuously tracks its location and transmits coordinates to the Blynk IoT platform. In emergency situations, the user can trigger an alert that sends a notification along with a live Google Maps location link to caregivers. The system also allows remote monitoring and locating of the wheelchair through a mobile application.

Additionally, the wheelchair supports dual-mode control: manual operation using a joystick and voice-based control via serial commands. A buzzer is included for alert and horn functions to improve safety.

Overall, this project provides a cost-effective, reliable, and user-friendly assistive solution by combining mobility, safety, communication, and IoT-based monitoring. It significantly improves the independence and quality of life for differently-abled individual

## Keywords:

- IoT-based smart wheelchair
- Assistive technology
- Physically challenged individuals
- Wi-Fi-enabled control (ESP8266)
- Real-time GPS tracking
- Emergency alert system
- Voice control
- Joystick control
- Multi-mode operation
- Communication aid
- Remote monitoring
- Blynk IoT platform

## I. INTRODUCTION

The development of an IoT-based smart wheelchair system represents a transformative advancement in assistive technology, specifically designed to empower physically challenged and elderly individuals who struggle with independent mobility and communication. Unlike traditional manual or basic electric wheelchairs that offer limited

functionality and high caregiver dependency, this intelligent system integrates embedded electronics and Internet of Things (IoT) connectivity to provide a comprehensive healthcare solution. By utilizing an ESP8266 microcontroller and GPS technology, the wheelchair enables real-time location tracking and remote monitoring through mobile applications, ensuring that caregivers can track the user's position for enhanced safety.



To accommodate varying levels of physical ability, the system features a dual-mode control interface, allowing navigation via an intuitive manual joystick or hands-free voice commands. Furthermore, it incorporates a vital assistive communication layer where dedicated push-buttons trigger pre-recorded voice outputs for essential needs like "food," "water," or "washroom," bridging the gap for users with speech impairments. Safety is prioritized through an emergency alert mechanism that instantly transmits the user's live Google Maps coordinates to family members during a crisis. Ultimately, by combining seamless navigation, automated communication, and wireless monitoring, this project significantly improves the autonomy, safety, and overall quality of life for its users.

## II. LITERATURE REVIEW

**Kulkarni et al. (2020).**[1] demonstrated that integrating voice recognition (using modules like the HC-05 or smartphone-based processing) significantly improves accessibility for users with limited upper-limb mobility. Your project builds on this by implementing a "Changeover" switch (Push pin), allowing the user to toggle between manual joystick precision and the ease of voice commands.

**S. Raj (2019).**[2] discussed the importance of "Teach and Repeat" modes in robotic platforms. By using an Arduino-based controller to map x-axis and y-axis inputs to specific motor states (Forward, Backward, Left, Right), developers can create a predictable and low-latency navigation experience.

### **IoT Integration and Remote Monitoring.**[3]

The shift toward the Internet of Things (IoT) has allowed wheelchairs to become "connected devices."

**Mohammad et al. (2021).**[4] explored the use of the **Blynk IoT platform** for real-time monitoring. Their research highlighted that providing caregivers with a virtual dashboard to monitor the wheelchair's status reduces the response time during accidents.

**P. Verma & R. Kumar (2022).**[5] conducted a study on "Emergency Alert Systems for the Elderly," where they used **Tiny GPS++** libraries to parse NMEA data. They found that sending direct Google Maps links during an emergency significantly aids recovery efforts.

**G.SAI RAJ ET ALL (2025).**[6] voice-controlled wheel chair, Bluetooth-enabled wheelchairs combined with smartphone applications provide convenient and accessible control for improved user mobility.

### III. METHODOLOGY

The development of a smart wheelchair methodology begins with a clear **Requirement Mapping** and **System Architecture** phase, where the Arduino Uno is designated as the primary "brain" for motor control while the ESP8266 handles the "communication" via GPS and IoT. This is followed by a rigorous **Hardware Integration** stage that emphasizes power management, ensuring a common ground between microcontrollers while isolating high-current motor power to prevent logic interference. Physical assembly requires strategic placement of sensors, such as mounting the GPS at the highest point for satellite clarity and installing an accessible **Manual/Voice toggle switch** on pin A1. During the **Software Development** phase, the Arduino's movement logic is calibrated using specific joystick thresholds—typically values below 100 or above 900—while the ESP8266 is integrated with the Blynk cloud platform using virtual pins V1 through V5 and the TinyGPS++ library.

To ensure system reliability, the process moves into **Sub-System Validation**, where "dry runs" are performed via the Serial Monitor to verify commands before the wheels are physically engaged. A critical **Failsafe Testing** step is then conducted to confirm that the emergency trigger on pin D7 successfully pushes GPS coordinates and mobile notifications within a 10-second window. Finally, the methodology concludes with **System Ruggedization**, involving the soldering of all breadboard connections onto a permanent PCB and securing components with standoffs to withstand the vibrations and physical demands of daily wheelchair movement.

### IV. COMPONENTS USED

#### ESP8266 (IoT Module)

The **ESP8266** is a highly versatile, low-cost Wi-Fi SoC (System on a Chip) that has revolutionized the development of Internet of Things (IoT) applications. It integrates a powerful 32-bit RISC microprocessor, typically the Tensilica L106, which allows it to handle complex networking tasks while simultaneously managing onboard processing and storage.

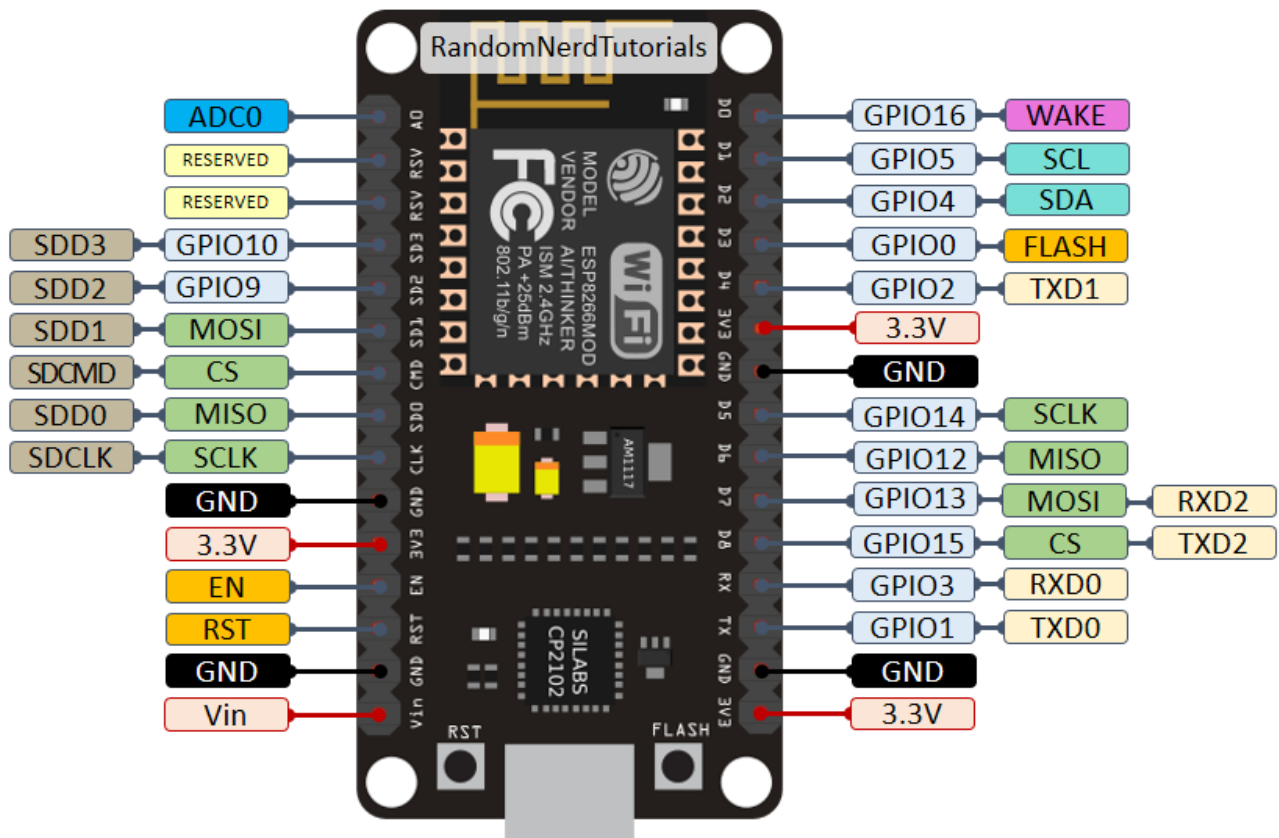

Figure.1: ESP8266 MODULE

The module is renowned for its full TCP/IP stack, enabling seamless connectivity to the internet or local networks via standard protocols like HTTP and MQTT. Despite its compact form factor, it features multiple GPIO pins for interfacing

with various sensors and actuators, making it a standalone controller for smart devices. Designed with energy efficiency in mind, it supports multiple power-saving states, such as deep sleep, which is critical for battery-operated remote projects. Furthermore, its compatibility with popular development environments like the Arduino IDE and Micro Python has fostered a massive global ecosystem, providing hobbyists and engineers alike with extensive libraries and community support for building everything from simple weather stations to complex industrial monitoring systems.

### GPS Module Integration

Integrating a GPS module into an IoT framework enables precise location tracking by establishing a serial communication link, typically via **UART**, between the module and a microcontroller. The module functions by receiving signals from a network of satellites, calculating coordinates through trilateration, and outputting this data in standardized **NMEA sentences**.

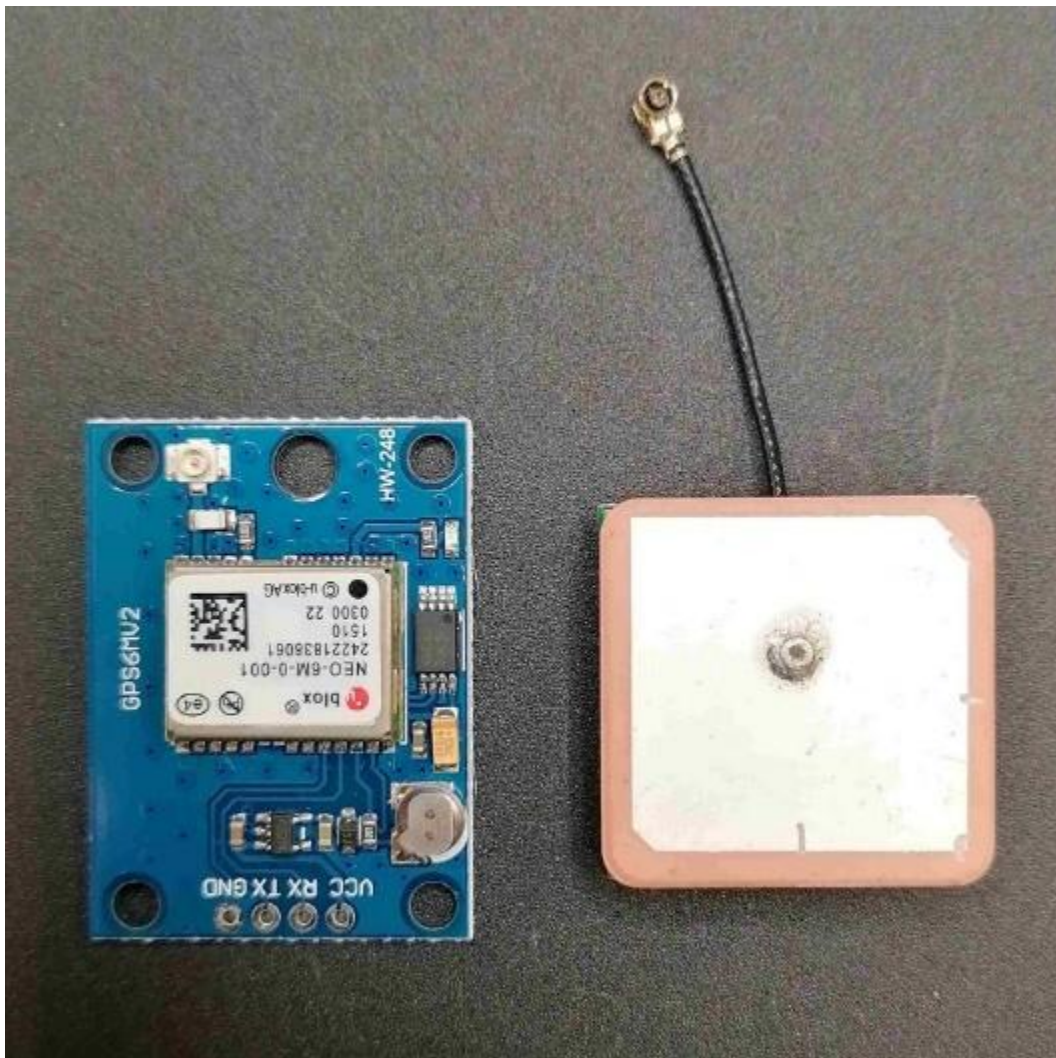

Figure.2: GPS Module Integration

To make this information useful, developers use parsing libraries like **Tiny GPS++** to extract specific variables such as latitude, longitude, and altitude from the raw text strings. Hardware success depends heavily on antenna placement, as a clear line of sight to the sky is required to achieve a satellite "lock" and minimize signal drift. Beyond simple positioning, GPS integration provides a highly accurate **UTC timestamp**, which is invaluable for synchronizing data across distributed sensor networks. In mobile or battery-powered applications, managing the power consumption of the GPS chip is vital, often requiring the implementation of sleep modes to extend device longevity. This combination of spatial and temporal data allows for advanced features like geofencing, asset tracking, and automated environmental mapping.

## Motor Driver and DC Motors

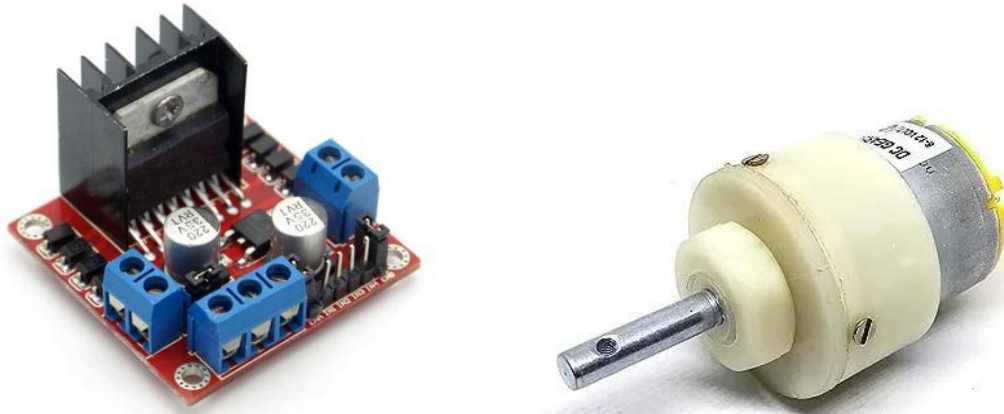

Figure.3: L298N MODULE & DC MOTOR

## Joystick Interface



Figure.4: Joystick Interface

The joystick module is connected to analog pins of the Arduino. It provides X and Y axis values, which are used to determine the direction of movement.

## Push Buttons (Emergency & Communication)



Figure.5: PUSH BUTTON

Push buttons serve as the primary physical interface for user interaction in IoT systems, facilitating immediate digital responses through simple mechanical action. In emergency scenarios, they provide a reliable, low-latency method for triggering instant alerts or distress signals to caregivers or central monitoring stations. Beyond safety, these buttons allow for seamless mode switching, enabling users to toggle between different device configurations or operational states. For assistive communication, dedicated buttons can be programmed to represent specific needs such as food, water, or medical assistance, promoting independence for individuals with limited mobility. Their tactile feedback and ease of integration make them indispensable for creating accessible and responsive hardware environments.

**Buzzer / Voice Output Unit**

Figure.6: Buzzer / Voice Output Unit

The **Buzzer and Voice Output Unit** serves as the primary acoustic signalling component, providing immediate audible feedback to the user or surroundings. It is essential for issuing high-priority alerts, such as emergency alarms or system status notifications, ensuring that critical events are noticed even when the user is not looking at a screen. While standard buzzers provide simple tonal pips for interaction confirmation, advanced voice modules can play pre-recorded audio for specific requests like "water" or "assistance." This dual-capability enhances accessibility, allowing for a more intuitive and responsive communication interface in assistive technology. Its low power requirement and straightforward integration make it an ideal choice for compact, battery-operated IoT devices.

**V. WORKING**

The IoT Wheelchair functions as an integrated smart system that merges physical mobility with remote safety monitoring. At its core, the **Arduino Nano** acts as the primary controller for movement, utilizing a dual-input method toggled by a mode-switch button. In manual mode, the Arduino reads analog signals from a **Joystick**, translating physical tilt into motor commands. In wireless mode, it receives serial data via the **HC-05 Bluetooth module**, allowing the user to control the chair through voice or app commands. These signals are sent to the **L298N Motor Driver**, which manages the high-current power required to drive the two DC motors. By using differential drive logic—switching the polarity of the OUT1-OUT4 terminals—the system can achieve forward, backward, and zero-radius turning maneuvers.

Simultaneously, the **NodeMCU (ESP8266)** operates as a dedicated IoT gateway to ensure the user's safety. It interfaces with a **Neo-6M GPS module** to constantly track the wheelchair's real-time coordinates, which are then uploaded to the **Blynk Cloud**. If the user presses the **Emergency Button**, the NodeMCU immediately triggers a cloud alert that sends a push notification to a caregiver's smartphone, complete with a clickable Google Maps link. This separation of tasks—where the Arduino handles real-time motor control and the NodeMCU handles long-range communication—ensures that the wheelchair remains responsive even during network lag. A system of buzzers provides audible feedback for commands, low-battery warnings, or emergency confirmations, creating a safe and interactive environment for the user.

**VI. RESULT**

The developed IoT-based smart wheelchair system successfully integrates advanced mobility and assistive technologies to enhance the independence and safety of physically challenged individuals. The system features a dual-control navigation setup, allowing users to move seamlessly via an accurate analog joystick or a responsive voice-command module that recognizes directional prompts like "front" and "stop." For enhanced safety, a GPS-enabled tracking system communicates through an ESP8266 Wi-Fi module to the Blynk IoT platform, providing real-time location data and Google Maps links to caregivers. This connectivity is bolstered by an emergency alert mechanism that sends immediate notifications with coordinate data at the push of a button. Beyond mobility, the wheelchair includes an assistive communication feature that generates predefined voice outputs for basic needs like "food" or "water," specifically aiding those with speech impairments.



Figure.7: Iot based wheel chair

The entire hardware architecture, split between an Arduino for motor logic and an ESP8266 for cloud communication, operates with low power consumption and high reliability.



Ultimately, the system provides a user-friendly, battery-efficient solution that performs consistently under various operating conditions without technical interference.

### REFERENCES

- [1]. Arduino IDE Documentation, “Arduino Programming and Hardware Interface Guide,” Available: <https://www.arduino.cc>
- [2]. Blynk IoT Platform Documentation, “Blynk IoT Platform User Guide,” Available: <https://blynk.io>
- [3]. TinyGPS++ Library by Mikal Hart, “GPS Data Processing Library for Arduino,” Available: <https://github.com/mikalhart/TinyGPSPlus>
- [4]. ESP8266 WiFi Library Documentation, “ESP8266 WiFi Module Programming Guide,” Available: <https://arduino-esp8266.readthedocs.io>
- [5]. K. M. Passino, “Smart Wheelchair Control Systems,” *IEEE Control Systems Magazine*, vol. 17, no. 1, pp. 10–17, 1997.
- [6]. R. Simpson, “Smart Wheelchairs: A Literature Review,” *Journal of Rehabilitation Research and Development*, vol. 42, no. 4, pp. 423–436, 2005.
- [7]. Global Positioning System (GPS) Documentation, “GPS Technology and Applications,” Available: <https://www.gps.gov>
- [8]. D. Cook and S. Das, *Smart Environments: Technology, Protocols and Applications*, Wiley Publications, 2004.
- [9]. Espressif Systems, “ESP8266 Technical Reference Manual,” Available: <https://www.espressif.com>
- [10]. A. Pandey et al., “IoT Based Smart Wheelchair for Disabled and Elderly People,” *International Journal of Research in Engineering and Technology*, 2020.