

DESIGN AND IMPLEMENTATION OF A PIC-BASED PHASE FAILURE AND THERMAL PROTECTION SYSTEM FOR THREE-PHASE INDUCTION MOTORS

**Dr. M. SARITHA¹, PAWAR ADITHYA², EPPA PRANAYA³, DAYYALA BALAJI⁴,
NELLUTLA YOGI⁵**

Assistant Professor, Department of Electrical and Electronics Engineering, Matrusri Engineering College, Hyderabad, Telangana, India¹

Students, Department of Electrical and Electronics Engineering, Matrusri Engineering College, Hyderabad, Telangana, India^{2,3,4,5}

I. ABSTRACT

Three-phase induction motors are widely used in industrial applications but are highly vulnerable to faults such as phase failure and excessive temperature rise, which can lead to severe damage and reduced operational life. This paper presents the design and implementation of a microcontroller-based protection system using PIC16F72 to detect and prevent such faults. The system continuously monitors phase conditions using voltage sensing circuits and measures motor temperature using an LM35 sensor. Upon detecting abnormal conditions such as phase loss or overheating, the system automatically disconnects the motor supply using a relay mechanism. The proposed system provides real-time monitoring, fast response, and improved reliability, making it suitable for industrial motor protection applications.

The microcontroller processes these inputs and triggers a relay mechanism to disconnect the motor supply whenever abnormal conditions are detected. The proposed system ensures fast response, improved reliability, and reduced maintenance costs. The design is simple, cost-effective, and suitable for small and medium-scale industrial applications.

Keywords: Three-Phase Induction Motor, PIC16F72 Microcontroller, Phase Failure Detection, Temperature Monitoring, Motor Protection System, Relay Control, LM35 Sensor

II. INTRODUCTION

Three-phase induction motors are the backbone of industrial operations due to their high efficiency, rugged construction, and low maintenance requirements. These motors are extensively used in applications such as pumps, compressors, conveyors, and fans. Despite their advantages, they are highly sensitive to electrical disturbances such as phase loss, voltage imbalance, and overheating. Among these, phase failure is one of the most severe faults that can cause excessive current flow in remaining phases, leading to overheating and insulation damage. Similarly, prolonged operation under high temperature conditions reduces motor lifespan and increases the risk of breakdown. Traditional protection methods such as thermal relays and fuses are often slow and do not provide continuous monitoring. Therefore, there is a need for a smart, real-time protection system that can detect faults early and respond quickly. Thus, to overcome these limitations, a microcontroller-based protection system is proposed in this work. The system continuously monitors phase conditions and temperature levels using sensors and automatically disconnects the motor supply in case of abnormal conditions. This approach enhances safety, improves reliability, and reduces maintenance costs.

III. LITERATURE SURVEY

Several researchers have contributed to the development of protection systems for three-phase induction motors by focusing on fault detection, monitoring techniques, and automated control systems.

B. K. Bose (2002) in *Modern Power Electronics and AC Drives* discussed the importance of monitoring electrical parameters such as voltage, current, and temperature to prevent motor failure. The work emphasized the role of power electronic converters and control strategies in improving motor protection and efficiency. However, the approach mainly focuses on drive systems rather than low-cost protection solutions.

P. C. Krause, O. Wasynczuk, and S. D. Sudhoff (2013) in *Analysis of Electric Machinery and Drive Systems* provided a detailed mathematical analysis of induction motor behavior under normal and fault conditions. Their work explained how phase failure and voltage imbalance lead to overheating and efficiency reduction. Although the study offers strong theoretical insight, it does not provide a practical implementation for real-time protection systems.

M. H. Rashid (2014) in Power Electronics: Circuits, Devices and Applications highlighted the use of electronic circuits and embedded systems in improving the reliability of electrical systems. The study emphasized the role of microcontroller-based protection systems in detecting abnormal conditions and controlling system operation. However, it lacks specific implementation details for motor fault protection.

S. N. Singh and R. K. Srivastava (2019) proposed a Microcontroller-Based Protection System for Three-Phase Induction Motors, where sensors were used to monitor voltage and temperature conditions. Their system demonstrated that automatic detection and isolation of faults significantly improves motor safety. The limitation of this system is its restricted focus on basic fault detection without advanced monitoring capabilities.

A. K. Gupta and P. Sharma (2021) developed a Smart Monitoring and Protection System for Three-Phase Induction Motors using sensor-based techniques. Their work showed improved fault detection accuracy and system reliability by integrating multiple sensing parameters. However, the system complexity and cost may increase with additional features.

J. Faiz and B. M. Ebrahimi (IEEE Transactions on Energy Conversion) presented advanced fault diagnosis techniques for induction motors using analytical and sensor-based approaches. Their research focused on identifying fault patterns and improving diagnostic accuracy. However, such techniques require complex computation and are not suitable for low-cost embedded systems.

Based on the above studies, it is evident that microcontroller-based protection systems offer a reliable and efficient solution for detecting phase failure and temperature-related faults. The proposed system builds upon these concepts by integrating phase detection and thermal monitoring using a PIC16F72 microcontroller to provide a simple, cost-effective, and real-time protection mechanism.

IV. PROPOSED WORK

The proposed system consists of a PIC16F72 microcontroller, voltage sensing circuits, an LM35 temperature sensor, a relay driver circuit, and a regulated power supply. The voltage sensing unit continuously monitors each phase of the three-phase supply. If any phase is lost or drops below a specified threshold, a signal is sent to the microcontroller. The LM35 sensor provides an analog voltage proportional to temperature, allowing accurate thermal monitoring. The microcontroller processes these signals and compares them with predefined limits. When abnormal conditions are detected, the controller activates the relay driver to disconnect the motor supply instantly. This ensures protection against both electrical and thermal faults.

V. BLOCK DIAGRAM

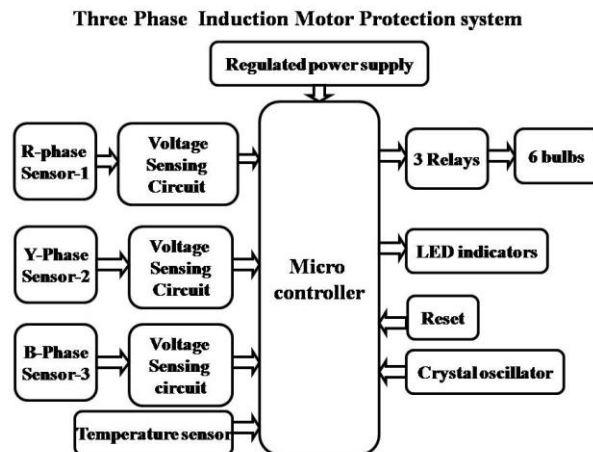

Fig.1.BlockDiagram

The block diagram illustrates the overall structure and functional flow of the proposed three-phase induction motor protection system. The system is designed to continuously monitor the phase conditions and temperature of the motor and to provide automatic protection under fault conditions. The input section consists of three phase sensing units corresponding to the R, Y, and B phases of the supply. Each phase is connected to a voltage sensing circuit that detects the presence or absence of voltage. These circuits convert the high AC voltage into a suitable low-level signal that can be processed by the microcontroller. This arrangement enables the system to identify phase failure or voltage imbalance conditions. In addition to phase monitoring, a temperature sensor is used to measure the motor winding temperature. The sensor continuously provides an analog output proportional to temperature, allowing real-time thermal monitoring. This

helps in detecting overheating conditions that may damage the motor insulation. The central processing unit of the system is the microcontroller, which receives input signals from both the voltage sensing circuits and the temperature sensor. The microcontroller processes these inputs and compares them with predefined threshold values. If any abnormal condition such as phase loss or excessive temperature is detected, it generates a control signal to activate the protection mechanism. The output section consists of a relay driver circuit connected to relays, which act as switching devices to disconnect the motor from the power supply during fault conditions. LED indicators are also included to provide visual indication of system status and fault conditions. A reset circuit is provided to restart the system after fault clearance, and a crystal oscillator ensures proper timing and execution of microcontroller operations. Thus, the entire system operates as an integrated protection unit that ensures reliable monitoring, quick fault detection, and automatic isolation of the motor supply, thereby enhancing safety and operational efficiency.

VI. CIRCUIT DIAGRAM

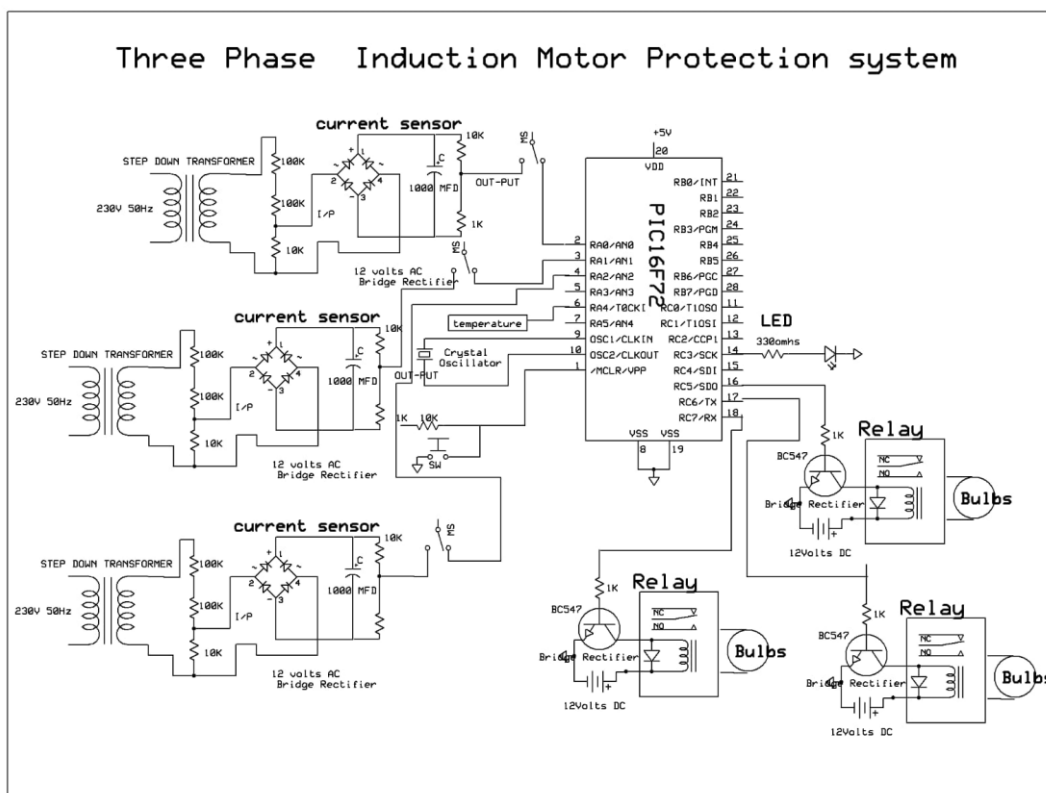

Fig.2.Circuit diagram

VII. HARDWARE COMPONENTS

PIC16F72 Microcontroller: The PIC16F72 microcontroller acts as the central processing unit of the system, responsible for monitoring input signals and executing control logic. It receives inputs from voltage sensing circuits and the temperature sensor and compares them with predefined thresholds. Based on these conditions, it controls the relay driver to disconnect the motor during faults. The microcontroller provides reliable, real-time decision-making with low power consumption and high efficiency.



Fig.1. PIC16F72 Microcontroller

Voltage Sensing Circuit: The voltage sensing circuit is used to detect the presence and condition of each phase in the three-phase supply. It reduces the high AC voltage to a safe level suitable for microcontroller input using resistive dividers and signal conditioning components. The circuit converts the AC signal into a readable form, enabling the system to identify phase failure or voltage imbalance. This ensures accurate detection of electrical faults in the motor supply.

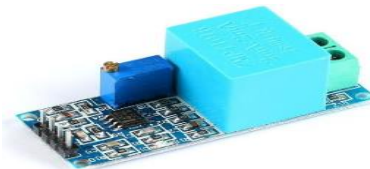

Fig.2. Voltage Sensing Circuit

LM35 Temperature Sensor: The LM35 temperature sensor is used to monitor the temperature of the motor winding continuously. It provides an analog output voltage that is linearly proportional to temperature in degrees Celsius. The sensor offers high accuracy and does not require additional calibration. When the temperature exceeds the preset limit, the sensor signal enables the microcontroller to initiate protective action, preventing overheating damage.

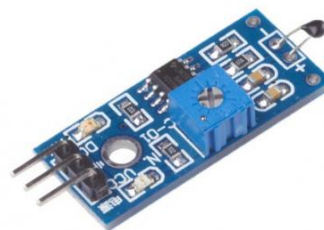

Fig.3.LM35 Temperature Sensor

Relay with Driver Circuit: The relay driver circuit is used to control the operation of the relay based on signals from the microcontroller. Since the microcontroller cannot directly drive high-power devices, a transistor-based driver is used to amplify the control signal. The relay acts as an electromechanical switch that disconnects the motor from the power supply during fault conditions. This ensures immediate isolation and protects the motor from damage.

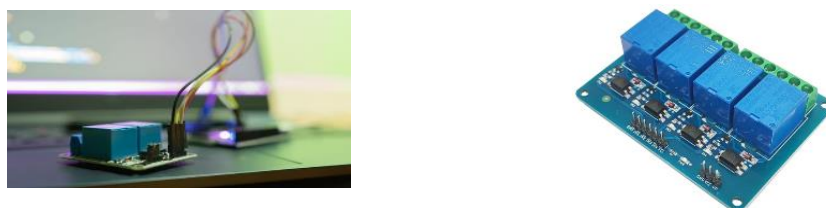

Fig.4. Relay with Driver Circuit

Regulated Power Supply: The regulated power supply provides a stable DC voltage required for the operation of the

microcontroller and associated electronic components. It converts the AC mains supply into a filtered and regulated DC output using rectifiers, filters, and voltage regulators. A stable power supply is essential for accurate sensing and reliable system performance. It prevents fluctuations that could affect the operation of the control system.

LED indicators: LED indicators display the system's operating status and indicate fault conditions. They provide visual feedback for normal operation, phase failure, and overheating conditions. This allows users to quickly identify system behavior without complex measurement tools. The LEDs improve system usability and assist in troubleshooting.

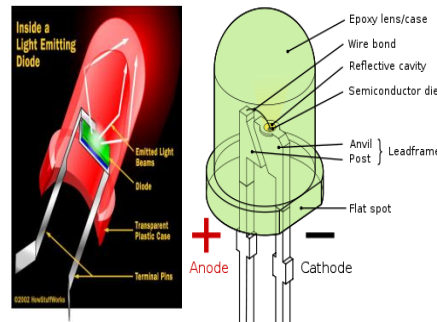

Fig.5. LED Indicators

Crystal Oscillator: The crystal oscillator provides precise clock signals required for the operation of the microcontroller. It determines the execution speed of instructions and ensures proper timing of system operations. Accurate timing is essential for reliable monitoring and control processes. The oscillator enhances system stability and synchronization.



Fig.6. Crystal Oscillator

VIII. WORKING

The proposed system operates on the principle of continuous monitoring and real-time fault detection of three-phase supply and motor temperature. Under normal operating conditions, all three phases (R, Y, B) are present, and the voltage sensing circuits produce corresponding signals that indicate healthy supply conditions. These signals are fed into the PIC16F72 microcontroller through appropriate signal conditioning circuits. Simultaneously, the LM35 temperature sensor continuously measures the temperature of the motor winding and provides an analog voltage output proportional to the temperature. This analog signal is converted into digital form using the internal ADC of the microcontroller. The microcontroller continuously compares the sensed values with predefined threshold limits programmed into the system. When a phase failure occurs, the corresponding voltage sensing circuit detects the absence of voltage and sends a fault signal to the microcontroller. Similarly, if the motor temperature exceeds the safe operating limit, the LM35 sensor output increases beyond the threshold level. In both cases, the microcontroller identifies the abnormal condition and immediately generates a control signal. This control signal is applied to the relay driver circuit, which energizes the relay and disconnects the motor from the power supply. The system also activates LED indicators to display the type of fault condition. Once the fault is cleared, the system can be reset manually to resume normal operation. Thus, the system ensures continuous monitoring, rapid fault detection, and automatic protection of the motor from electrical and thermal damage.

IX. IMPLEMENTATION

The proposed system is implemented using a combination of sensing circuits, embedded control, and switching mechanisms. The hardware design consists of a PIC16F72 microcontroller, voltage sensing circuits for each phase, an LM35 temperature sensor, a relay driver circuit, and a regulated power supply. The voltage sensing circuit is designed using resistive dividers and rectification stages to safely convert high AC voltage into a low-level DC signal suitable for

microcontroller input. Each phase (R, Y, B) is monitored independently to detect any phase loss or imbalance condition. The LM35 temperature sensor is physically placed near the motor winding to accurately sense temperature variations. Its analog output is connected to the ADC input pin of the microcontroller, allowing continuous temperature monitoring. The PIC16F72 microcontroller is programmed using embedded C to perform real-time monitoring and decision-making. The program continuously reads input signals, compares them with predefined threshold values, and determines whether the system is operating under normal or fault conditions. A transistor-based relay driver circuit is used to interface the microcontroller with the relay, enabling it to control high-power motor supply lines. LED indicators are connected to output pins to provide visual status of system operation. The entire system is powered using a regulated DC power supply, ensuring stable operation of all electronic components. The hardware is assembled on a PCB and tested under different operating conditions to verify performance communication, obstacle detection, and smooth operation of the robot.

X. RESULT

The proposed system successfully monitored the three-phase supply and motor temperature under normal operating conditions. Phase failure was accurately detected, and the motor supply was immediately disconnected through the relay. The temperature sensing unit effectively identified overheating conditions beyond the preset limit. The response time of the system was fast and reliable, preventing potential motor damage. LED indicators provided clear and instant fault status indication. Overall, the system demonstrated stable performance and effective protection under different fault conditions.

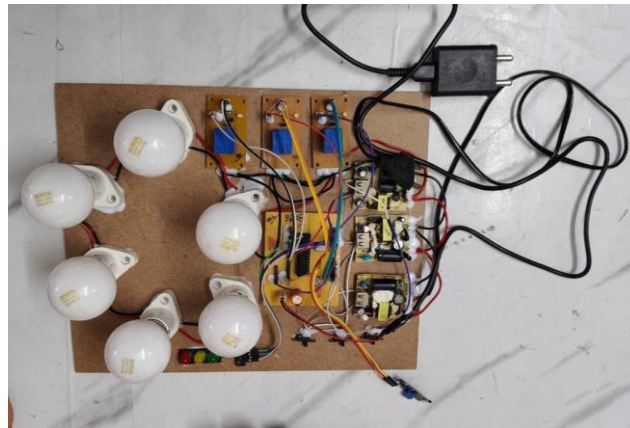

XI. CONCLUSION

In this work, a microcontroller-based protection system for three-phase induction motors has been successfully designed and implemented. The system effectively detects critical faults such as phase failure and excessive temperature rise, which are major causes of motor damage. By integrating voltage sensing circuits and a temperature sensor with a PIC16F72 microcontroller, the system provides continuous monitoring and real-time fault detection. The automatic relay-based disconnection mechanism ensures immediate protection, thereby enhancing motor safety and operational reliability. The proposed system is simple, cost-effective, and easy to implement, making it suitable for both industrial and small-scale applications. It reduces maintenance costs and increases the lifespan of the motor by preventing severe damage. Future improvements may include the integration of wireless communication modules, IoT-based monitoring, and advanced fault prediction techniques to further enhance system capabilities.

REFERENCES

- [1] B. K. Bose, *Modern Power Electronics and AC Drives*, Upper Saddle River, NJ, USA: Prentice Hall, 2002, fundamental concepts of motor control and protection systems.
- [2] P. C. Krause, O. Wasynczuk, and S. D. Sudhoff, *Analysis of Electric Machinery and Drive Systems*, 3rd ed., Hoboken, NJ, USA: Wiley, 2013, detailed analysis of motor behavior under fault conditions.
- [3] M. H. Rashid, *Power Electronics: Circuits, Devices and Applications*, 4th ed., Pearson Education, 2014, useful for understanding control circuits and protection design.
- [4] S. N. Singh and R. K. Srivastava, "Microcontroller-Based Protection System for Three-Phase Induction Motors," *International Journal of Electrical Engineering*, 2019, demonstrates embedded fault detection and control techniques.
- [5] A. K. Gupta and P. Sharma, "Smart Monitoring and Protection of Three-Phase Induction Motors," *International*



Journal of Engineering Research and Applications, 2021, focuses on sensor-based monitoring and improved system reliability.

[6] J. Faiz and B. M. Ebrahimi, "Induction Motor Fault Diagnosis Methods: A Review," IEEE Transactions on Energy Conversion, advanced diagnostic approaches for electrical and thermal faults.

[7] IEEE Standards Association, IEEE Std 242-2001: Protection and Coordination of Industrial Power Systems, New York, USA, 2001, standard guidelines for industrial motor protection practices.

[8] Texas Instruments, "LM35 Precision Centigrade Temperature Sensor Datasheet," Texas Instruments Inc., 2023, technical specifications and operating characteristics of temperature sensor.

[9] Microchip Technology Inc., "PIC16F72 Microcontroller Datasheet," Microchip Technology Inc., 2023, details about architecture, ADC features, and interfacing capabilities.